

# Power Quality Application Guide



## *Voltage Disturbances*

### *Considerations for Choosing the Appropriate Voltage Sag Mitigation Device*

5.3.4

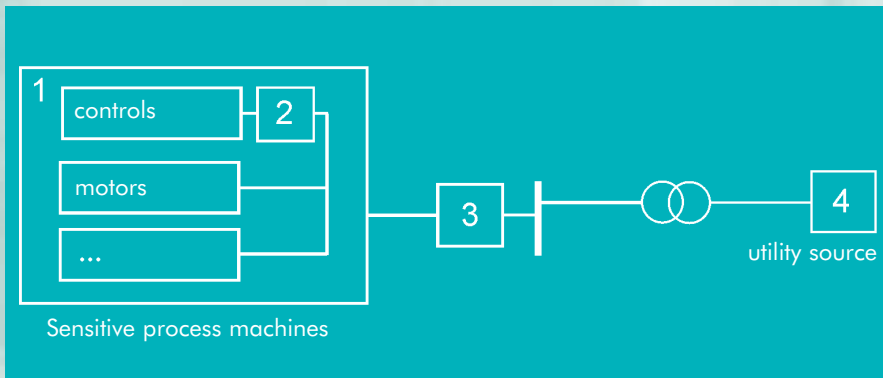

# Voltage Disturbances

## Considerations for Choosing the Appropriate Sag Mitigation Device

Dr ir Marcel Didden

Laborelec

April 2005



This Guide has been produced as part of the Leonardo Power Quality Initiative (LPQI), a European education and training programme supported by the European Commission (under the Leonardo da Vinci Programme) and International Copper Association. For further information on LPQI visit [www.lpqi.org](http://www.lpqi.org).



### Copper Development Association (CDA)

Copper Development Association is a non-trading organisation sponsored by the copper producers and fabricators to encourage the use of copper and copper alloys and to promote their correct and efficient application. Its services, which include the provision of technical advice and information, are available to those interested in the utilisation of copper in all its aspects. The Association also provides a link between research and the user industries and maintains close contact with the other copper development organisations throughout the world.

CDA is an IEE endorsed provider of seminar training and learning resources.



### European Copper Institute (ECI)

The European Copper Institute is a joint venture between ICA (International Copper Association) and the European fabricating industry. Through its membership, ECI acts on behalf of the world's largest copper producers and Europe's leading fabricators to promote copper in Europe. Formed in January 1996, ECI is supported by a network of eleven Copper Development Associations ('CDAs') in Benelux, France, Germany, Greece, Hungary, Italy, Poland, Russia, Scandinavia, Spain and the UK.

### Disclaimer

The content of this project does not necessarily reflect the position of the European Community, nor does it involve any responsibility on the part of the European Community.

European Copper Institute, Laborelec and Copper Development Association disclaim liability for any direct, indirect, consequential or incidental damages that may result from the use of the information, or from the inability to use the information or data contained within this publication.

Copyright© European Copper Institute, Laborelec and Copper Development Association.

Reproduction is authorised providing the material is unabridged and the source is acknowledged.

**LPQI is promoted in the UK by members of the Power Quality Partnership:**



# Voltage Disturbances

## Considerations for Choosing the Appropriate Voltage Sag Mitigation Device

### Introduction

This paper compares various systems for protecting industrial processes against voltage sags (flywheel, static UPS, dynamic voltage restorer, statcom, shunt connected synchronous motor and a transformerless series injector). These systems are compared with regard to dip immunisation capability and several other technical and economic parameters.

A voltage sag, as defined in EN 50160, is a decrease of the supply voltage of between -10 and -99% for a short time (<1 minute) [1]. Sags are known to be among the most costly power quality phenomena in industry. Different solutions exist to reduce the costs incurred due to sags: they are often structured in the four categories listed in Figure 1 [2].

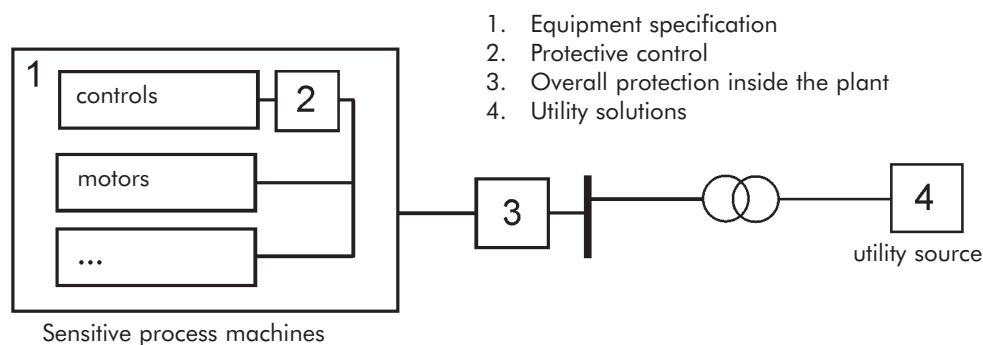

Figure 1- Possible mitigation methods [2]

Modifications in the process equipment itself (Nos 1 and 2 in Figure 1) tend to be the cheapest to implement but are not always possible because manufacturers have not made suitable equipment readily available in the market. (For variable speed drives, these options are discussed in Section 5.3.3). Modifying the grid, (No 4 in Figure 1), although an interesting option (discussed in Section 5.5.1), is not always possible and is likely to be very expensive. The only methods that can generally be applied are protective measures installed between the sensitive process and the grid (No 3 in Figure 1), and these are discussed in this section.

In theory, installing an uninterruptible power supply (UPS) is the easiest way to protect sensitive processes against all sags. However, due to its considerable purchase and maintenance costs, UPS equipment is installed on a structural basis only in places where the damage resulting from power supply problems is very high, such as in hospitals, computer facilities and financial institutions. In other cases, including most industrial processes, the installation of protective equipment must be subject to a cost-benefit analysis, which often shows that installing a UPS is too expensive [7].

Stimulated by the high prevalence of voltage sag problems in industrial processes due to equipment being sensitive to sags, solutions to protect equipment against these sags have been made commercially available. Due to the wide variety and exotic vendor specific names of these systems, choosing the optimal techno-economic solution for a given problem is not straightforward. This section analyses a number of systems that can be installed in existing facilities containing processes susceptible to voltage sags.

Taking into account sag statistics from various countries, this Section provides guidance on the effectiveness (in terms of the percentage of process outages avoided) that can be expected by installing these systems. Firstly, the equipment types are described. Subsequently the sag immunisation capability and other technical and economic aspects are evaluated. Taking into account the performance of the described systems with regard to these aspects, guidelines for practical situations are given.

## Types of mitigation equipment

### Flywheel

A flywheel and motor-generator (M/G) combination can protect critical processes against all voltage sags where the duration is shorter than the hold-up time of the flywheel. When a sag occurs, the motor-generator set feeds the load, the energy being supplied by the gradually slowing flywheel. Different connection topologies of the flywheel to the M/G-set exist, of which Figure 2 shows the main components of a connection using power electronics.

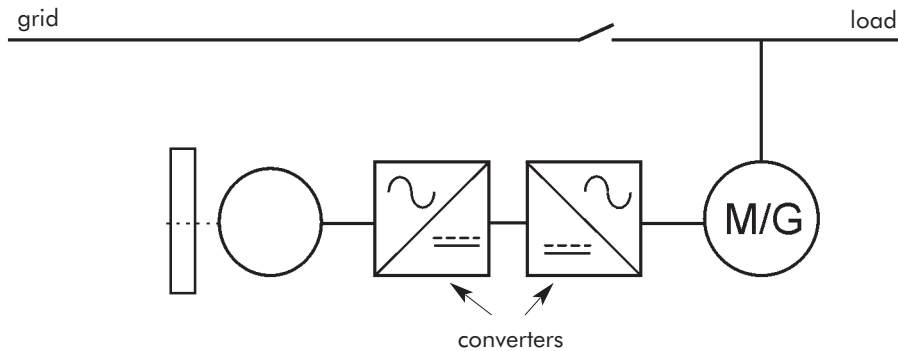

Figure 2 - Block diagram of a ride-through system using a flywheel

### Static UPS with minimal energy storage

Figure 3 shows the topology of a voltage frequency independent (VFI), online or double conversion, static UPS. These devices are primarily intended to maintain supply during supply interruptions by providing, for example, sufficient support to allow for an orderly shutdown of processes. During an interruption the load is fed from the battery through the dc/ac converter. If the unit is required only for protection against dips, the energy storage may be supplied by a capacitor; this arrangement is often described as a 'conditioner'.

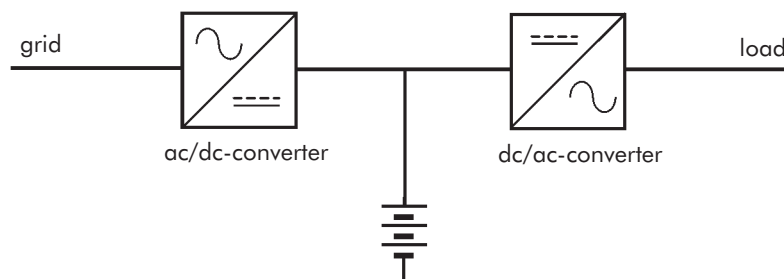

Figure 3 - Block diagram of a voltage frequency independent static UPS

### Dynamic voltage restorer (DVR)

During a voltage sag, a dynamic voltage restorer (DVR) adds the missing voltage through a transformer, installed in series with the load [5]. The load remains connected to the grid and the DVR calculates the missing part of the voltage waveform and corrects it. Depending on the concept, the energy to support the load during a sag originates either from the network or from an additional energy storage unit (usually a capacitor bank).

The first (hereafter called DVR-1) has no energy storage and is continuously on-line. When a dip occurs the energy to generate the required difference voltage is drawn from the supply (as an increased current) so the

device cannot cope with very low retained voltages. This type of DVR is commercially available with a voltage boost capability up to 50%. However, later analysis refers to a version with a boost capability of 30%, since this is considered to be the most cost-effective by manufacturers.

The second (Figure 4, hereafter called DVR-2) has energy storage and is more suitable for large loads. The unit is rated in terms of the power that can be injected; the voltage boost capability therefore depends on the load. A 2 MW unit can boost the voltage of a 4 MW load by 50%, or the voltage of an 8 MW load by 25%. In contrast with most other devices, the energy storage capacity is an issue for riding through longer sags. The type of energy storage is an important issue. Capacitors have relatively low storage density but recharge very quickly in preparation for the next supply defect, while high speed flywheels have large energy density but take a relatively long time to 'recharge'. These issues are discussed in detail in Section 4.3.1 of this Guide.

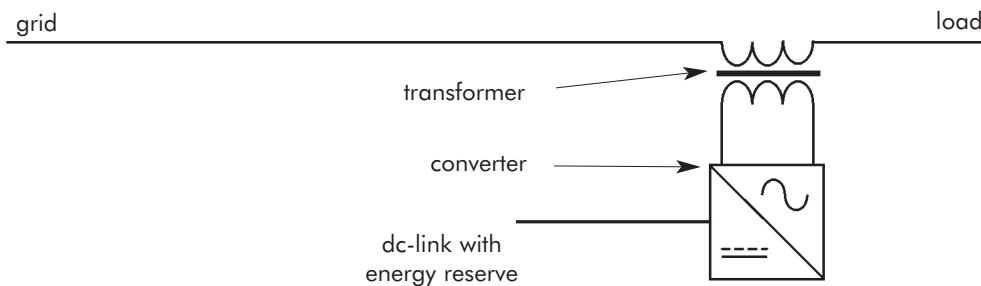

Figure 4 - Block diagram of a dynamic voltage restorer (DVR-2)

## Shunt connected synchronous machine

A shunt connected synchronous machine has some similarities with the statcom, but does not contain power electronics. The capability of the synchronous machine to supply large reactive currents enables this system to lift the voltage by 60% for at least 6 seconds. In addition, a small flywheel protects the load against full outages up to 100 ms (however this feature will not be considered further in the later analysis).

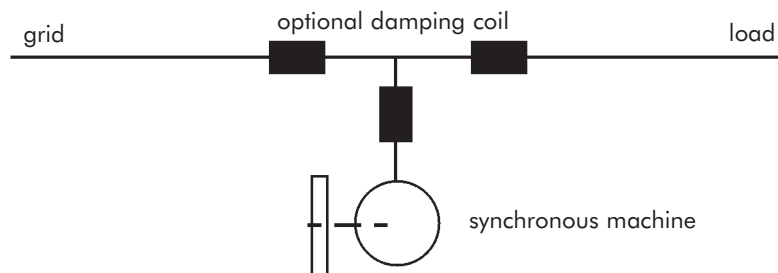

Figure 5 - Block diagram of shunt connected synchronous machine and flywheel

## Statcom

A static VAR compensator [5] is a current injector connected in parallel (shunt) with the load (Figure 6). A statcom mitigates voltage sags by injecting reactive power into the system. The sag mitigating capability can be enhanced by adding energy storage such as superconducting magnetic energy storage (SMES) [8].

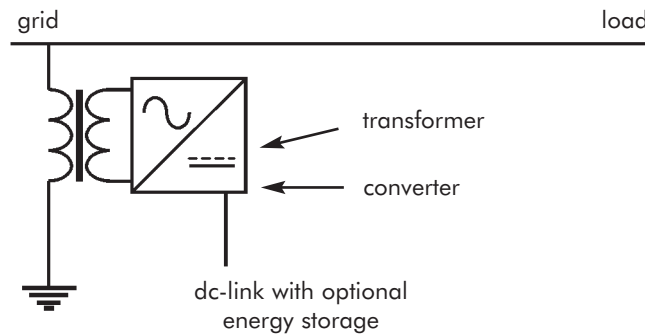

Figure 6 - Block diagram of a statcom

## Transformerless series injection

In the event of a voltage sag, the static switch of this series injection device (Figure 7) is opened and the load is supplied by an inverter. The power to the dc bus of the inverter is maintained by charging two capacitors connected in series. For sags down to 50% retained voltage, the rated voltage can be supplied to the load. Optional additional energy storage (e.g. extra capacitors) can mitigate a complete outage for a limited time duration and mitigate deeper asymmetrical sags, such as a complete outage of one phase. Only the basic operation is considered further.

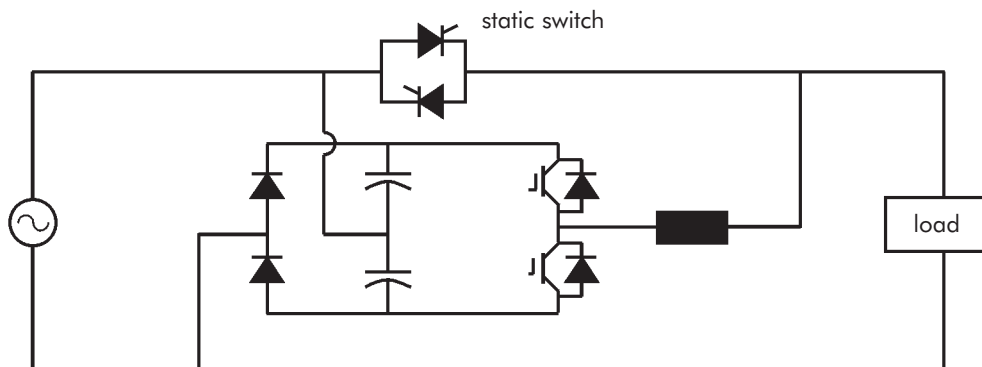

Figure 7 - Transformerless series injection

## Dip mitigation capability

This section compares the systems described above with regard to their dip mitigation capability. More precisely it analyses *the percentage of voltage sag induced equipment stoppages that will be mitigated*. Three important parameters are required to conduct a proper analysis:

- ◆ relative frequency of sags of a certain depth
- ◆ immunisation level
- ◆ sensitivity of the process.

## Relative frequency of sags with a certain depth

When comparing the different preventative solutions, the frequency of sags and the probability distribution of sag magnitudes is very important. One can imagine that an installation experiencing 10 sags per annum with a retained voltage of 10% requires a different solution from one with a similar number of sags but a retained voltage of 70%.

Figure 8 shows the voltage *reduction* against the percentage of sags that exceed or match it. The following statistics are used:

B1, B2:	Two MV busbars in Belgium
F:	MV busbar in France
NL:	MV busbar in The Netherlands
US:	DPQ Study in the US [1]
C:	Average of MV busbars in CIGRE report [4]

The duration of the sags is not taken into account since it is assumed that all systems are able to function for at least the maximum 2 second duration of a sag - although this is not a reasonable assumption for unprotected equipment in industry. The relative distribution shown in Figure 8 is assumed to be representative for all types of sags (1, 2 or 3 phases). As an example, point P in this figure indicates that 47% of the sags in the CIRED (C) statistics have a voltage drop less than 20% (i.e. a retained voltage greater than 80%).

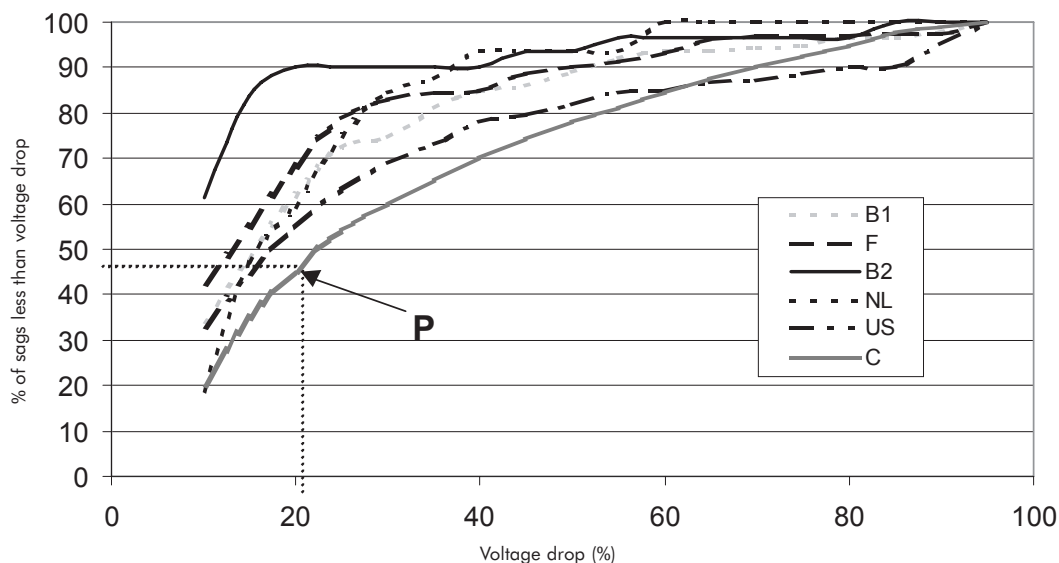

Figure 8 - Sag statistics from different countries, showing the percentage of sags less than a certain voltage drop in %

## Immunisation level

Three different concepts for enhancing immunity to voltage sags can be identified:

a) *Load is supplied by an external energy source*

These types of systems (flywheel and static UPS) can protect against all voltage sags. The time duration of the maximum protection depends only on the amount of the stored energy that can be utilised.

## b) The voltage is boosted by a certain percentage

These systems (statcom and DVR) use the remaining voltage in the grid as a starting point and add the missing voltage. If they cannot restore the nominal supply voltage, they use their maximum capability. A sag is considered to be mitigated if the final voltage (grid voltage during sag plus added voltage) is high enough to maintain normal operation of the load.

## c) The solution protects the load against a predefined sag magnitude

In order to retain a constant power flow to the load, these types of systems (e.g. transformerless series injection) compensate for the decreased voltage by drawing a higher current from the grid. Therefore, the maximum sag depth that can be compensated depends on the current rating of the mitigation equipment and the supply system.

## Sensitivity of the process

The sensitivity of the process is complex, being the result of the independent sensitivities - in terms of dip magnitude and duration - of the many individual items of equipment that co-operate to implement the 'process'. Reducing the overall (unprotected) sensitivity of the process to dips requires careful selection of equipment and an understanding of how the process 'fails' as the result of a dip.

It is often overlooked that the initial sensitivity of a process may have an impact on the percentage of process stoppages avoided by the protective equipment. However, this is of major importance when comparing systems within category b) and c), described earlier, as illustrated in Figure 9.

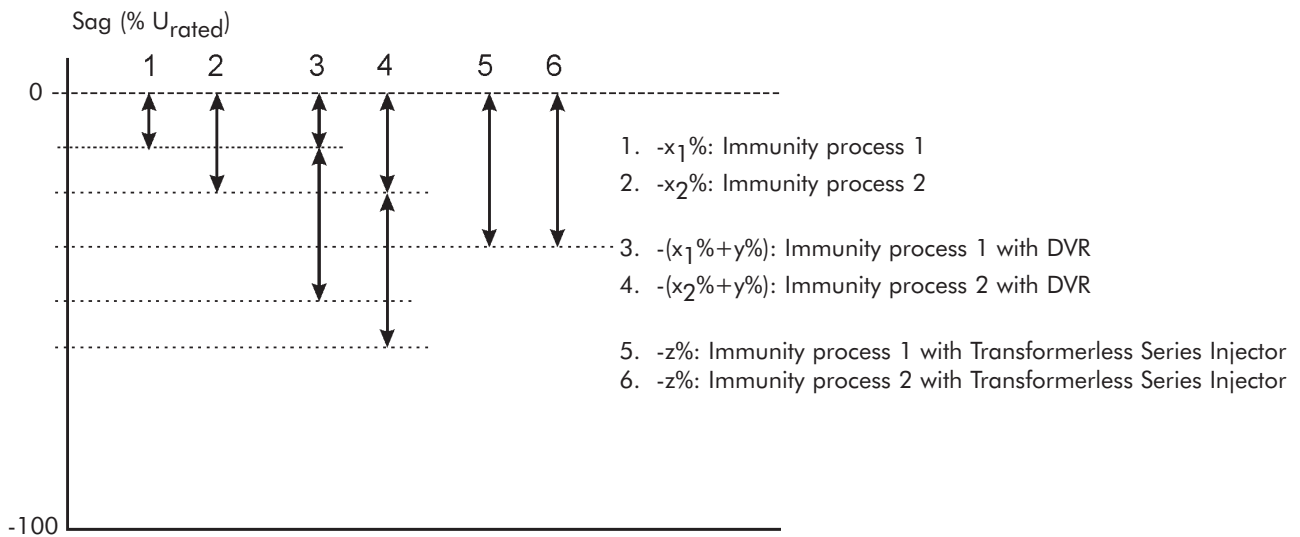

Figure 9 - Immunity of processes with different initial immunity with and without additional immunization equipment

Equipment in category b) will boost the voltage by a certain percentage. If a process that is immune to sags of  $-x\%$  is equipped with a system of category b), such as a DVR having a voltage boosting capability of  $+y\%$ , the process will be immune to voltage sags of  $-(x\%+y\%)$ .

On the other hand, equipment in category c) will immunise the process against sags of a predefined level (e.g.  $z\%$ ). By installing equipment of category c) the percentage of avoided process stoppages is less if the initial immunity of the process was  $-30\%$  compared to an initial immunity of  $-10\%$ .

## Summary of capability

Table 1 shows the percentage of process stoppages due to voltage sags that can be avoided by the described systems using sag statistics from the CIGRE report and one Belgian busbar (C and B2 in Figure 8) and taking into account two different levels of initial immunity of the process ( $-10\%$  and  $-30\%$ ). The percentage of

avoided stoppages is not affected by the vulnerability of the process equipment to 3 phase sags or to 1, 2 and 3 phase sags since the paper assumes that:

- ◆ the relative distribution of the sag depth is equal for all sags (1, 2 and 3 phase)
- ◆ all protective equipment provides the same relative protection for these sags.

Percentage of outages due to sags that will be reduced:  40 - 60% 60 - 80% 80 - 100%	Concept of immunization (section 0)	Maximum voltage drop being protected in %	Maximum voltage lift in %	'CIGRE busbar' (C), initial immunity - 10%	'CIGRE busbar' (C), initial immunity - 30%	Belgian busbar (B2), initial immunity - 10%	Belgian busbar (B2), initial immunity - 30%
	Flywheel	a	100	/			
Static UPS	a	100	/				
DVR-Cap1	b	/	30				
DVR-Cap2, 200% load	b	/	50				
DVR-Cap2, 400% load	b	/	25				
Statcom-SMES	b	/	60				
Shunt connected SM	b	/	60				
Transformerless series injection	c	50	/				

*Table 1 - Percentage of outages reduced by installing different mitigation devices, taking into account different sag statistics and different initial immunity of the processes.*

## Other technical and economic aspects

This section discusses some of the physical and performance characteristics of product categories currently available on the market in comparative terms. For each type, each characteristic is indicated as an advantage (+), neutral (=) or as a disadvantage(-).

### Size

Some systems are currently only available in sizes larger than 1 MW (-), while others are also sold in sizes smaller than or equal to 100 kW (+).

### Purchase cost

Since the decision to buy mitigation equipment to prevent damage due to voltage sags is the outcome of a cost-benefit analysis, the purchase price of the system is very important. Although contracts are made on an individual basis and can vary substantially, rough guidelines are provided for the purchase and installation cost of a medium-sized (between 100 kVA and 500 kVA) device if available.

Three price categories are defined:

- : > 250 euro per kVA
- = : 150-250 euro per kVA
- + : < 150 euro per kVA

## Maintenance

Depending on the type of system, the maintenance costs may be substantial. This paper only distinguishes whether annual maintenance is required (-) or not (+).

## Efficiency

Many systems require continuous electricity demand due to the use of power electronics, the use of moving parts (flywheel) or cooling (SMES), resulting in a reduction of the overall efficiency. Three categories are distinguished:

- + : losses <0.5% of rated power
- = : losses 0.5-2% of rated power
- : losses >2% of rated power

It should be noted that a low efficiency has significant impact on the economic decision making process. Taking into account an electricity cost of 0.05 euro/kWh and an efficiency of 97%, the annual loss is 13.1 euro per installed kW.

Considering an interest rate of 10%, the discounted losses in 10 years per kW will be 80.4 euro.

## Reaction time

Some of the protection devices need to detect the voltage sag before they can react. This may result in transient process behaviour.

The reaction (activation) time of the protective device is divided into three categories:

- + : reaction or activation transient < 1 ms
- = : transient 1-5 ms
- : transient > 5 ms

## Voltage harmonics

Some of the mitigation systems are also able to continuously compensate for voltage harmonics originating from the supplying network (+) while others do not influence voltage harmonics (=).

## Current harmonics

If the downstream load contains many power electronic applications, such as variable speed drives, the current will be highly non-linear. Some voltage sag mitigation systems have the ability to draw a linear current from the network despite the non-linear loads (+), while others do not influence current harmonics (=).

## Reactive power

Some applications have the ability to supply or draw reactive power continuously (+) while others cannot (=).

## Summary of technical and economic aspects

Table 2 summarises the performance of the described systems with regard to these parameters:

	Size	Purchase cost	Maintenance	Efficiency	Reaction time	Voltage harmonics	Current harmonics	Reactive power
Flywheel	+	-	-	-	=	+	+	+
Static UPS	+	-	-	-	+	+	+	+
DVR-1	+	+	+	=	=	=	=	+
DVR-2, 200% load	-	-	+	-	=	+	=	=
DVR-2, 400% load	-	=	+	-	=	+	=	=
Statcom-SMES	-	=	-	=	-	=	=	+
Shunt connected SM	+	=	-	-/=	=	+	+	+
Transformerless series injection	+	=	+	+	=	=	=	=

Table 2 - Technical and economic aspects of different mitigation methods

## Cost-benefit analysis of mitigation equipment

In order to analyse whether the expected reduction in outage cost outweighs the cost of the protective equipment, the following adapted version of the Net Present Value method can be used: [7]:

$$f \cdot p_{prev} \geq \frac{C_{inv}}{C_{sag}} x \left( \frac{(1+i)^n (i + p_{mnt}) - p_{mnt}}{(1+i)^n - 1} \right) \quad (1)$$

where

- $C_{inv}$  initial investment per kVA (Table 2)
- $f$  annual outages due to sags
- $p_{prev}$  percentage of outages being prevented (Table 1)
- $f \cdot p_{prev}$  annual mitigated outages
- $C_{sag}$  outage cost per sag per kVA
- $p_{mnt}$  maintenance costs per kVA per year as a percentage of  $C_{inv}$
- $i$  discount factor
- $n$  project time(a).

By introducing 'optimistic' values for a mitigation system (e.g.  $C_{inv}=100$  euro/kVA,  $p_{mnt}=0$ ,  $p_{prev}=100\%$ ), this formula can be used to determine whether the reduction in voltage sag losses will outweigh the cost of any of the described mitigation devices.

## Conclusions

It can be concluded that there is no single system superior in all situations. However, some guidelines can be given:

- ◆ A DVR having no energy storage or a transformerless series injector are most cost-effective. If harmonics and reactive power also cause problems, the shuntconnected synchronous motor could also be considered.
- ◆ It has also been shown that the percentage of outages being prevented by a certain solution depends on different parameters and cannot be predicted without statistical data on the sags. If all sags and short interruptions have to be mitigated, the only possible solution is installing a flywheel or a static UPS.

## References and Bibliography

[1] CENELEC, EN 50160, Nov 1999.

[2] Dugan, R; McGranaghan, M; Beaty, H: *Electrical Power Systems Quality*, Knoxville/USA: McGraw-Hill, 1996.

[3] EPRI, 'DPQ study final report', 1996.

[4] Beaulieu G et al, *Power quality indices and objectives for MV, HV and EHV systems CIGRE WG 36.07/CIREC progress*, CIREC 2003.

[5] Hingorani N, Gyugyi L, *Understanding FACTS*, Wiley IEEE Press, ISBN 0-7803-3455-8, 1999.

[6] van Zyl A, Spee R, Faveluke A, Bhowmik S, *Voltage sag ride-through for adjustable-speed drives with active rectifiers*, *IEEE Transactions on Industry Applications*, Vol. 34, pp 1270-1277, Nov/Dec 1998.

[7] Didden M, Belmans R, D'haeseleer W, *Cost-benefit analyses of voltage sag mitigation methods in textile extrusion plants*, *European Transaction of Electrical Power* Vol.13 No 2, Mar/Apr 2003.

[8] Nelson B (AM Superconductor Corporation), *Improving power quality inside the fab voltage sag correction using shunt inverter technology and stored energy*, *Future Fab International*, Issue 13, July 2002.

In addition, manufacturers' published information has been used.

## Reference & Founding\* Partners

European Copper Institute* (ECI) <i>www.eurocopper.org</i>	ETSII - Universidad Politécnica de Madrid <i>www.etsii.upm.es</i>	LEM Instruments <i>www.lem.com</i>
Akademia Gorniczko-Hutnicza (AGH) <i>www.agh.edu.pl</i>	Fluke Europe <i>www.fluke.com</i>	MGE UPS Systems <i>www.mgeups.com</i>
Centre d'Innovació Tecnològica en Convertidors Estàtics i Accionaments (CITCEA-UPC) <i>www.citcea.upc.edu</i>	Hochschule für Technik und Wirtschaft* (HTW) <i>www.htw-saarland.de</i>	Otto-von-Guericke-Universität Magdeburg <i>www.uni-magdeburg.de</i>
Comitato Elettrotecnico Italiano (CEI) <i>www.ceiuni.it</i>	Hogeschool West-Vlaanderen Departement PIH <i>www.pih.be</i>	Polish Copper Promotion Centre* (PCPC) <i>www.miedz.org.pl</i>
Copper Benelux* <i>www.copperbenelux.org</i>	International Union for Electricity Applications (UIE) <i>www.uie.org</i>	Università di Bergamo* <i>www.unibg.it</i>
Copper Development Association* (CDA UK) <i>www.cda.org.uk</i>	ISR - Universidade de Coimbra <i>www.isr.uc.pt</i>	University of Bath <i>www.bath.ac.uk</i>
Deutsches Kupferinstitut* (DKI) <i>www.kupferinstitut.de</i>	Istituto Italiano del Rame* (IIR) <i>www.iir.it</i>	The University of Manchester <i>www.manchester.ac.uk</i>
Engineering Consulting & Design* (ECD) <i>www.ecd.it</i>	Katholieke Universiteit Leuven* (KU Leuven) <i>www.kuleuven.ac.be</i>	Wroclaw University of Technology* <i>www.pwr.wroc.pl</i>
EPRI Solutions Inc <i>www.epri.com/eprisolutions</i>	Laborelec <i>www.laborelec.com</i>	

## Editorial Board

David Chapman (Chief Editor)	CDA UK	david.chapman@copperdev.co.uk
Prof Angelo Baggini	Università di Bergamo	angelo.baggini@unibg.it
Dr Araceli Hernández Bayo	ETSII - Universidad Politécnica de Madrid	ahernandez@etsii.upm.es
Prof Ronnie Belmans	UIE	ronnie.belmans@esat.kuleuven.ac.be
Dr Franco Bua	ECD	franco.bua@ecd.it
Jean-Francois Christin	MGE UPS Systems	jean-francois.christin@mgeups.com
Prof Anibal de Almeida	ISR - Universidade de Coimbra	adealmeida@isr.uc.pt
Hans De Keulenaer	ECI	hdk@eurocopper.org
Prof Jan Desmet	Hogeschool West-Vlaanderen	jan.desmet@howest.be
Dr ir Marcel Didden	Laborelec	marcel.didden@laborelec.com
Dr Johan Driesen	KU Leuven	johan.driesen@esat.kuleuven.ac.be
Stefan Fassbinder	DKI	sfassbinder@kupferinstitut.de
Prof Zbigniew Hanzelka	Akademia Gorniczko-Hutnicza	hanzel@uci.agh.edu.pl
Stephanie Horton	LEM Instruments	sho@lem.com
Dr Antoni Klajn	Wroclaw University of Technology	antoni.klajn@pwr.wroc.pl
Kees Kokee	Fluke Europe BV	kees.kokee@fluke.nl
Prof Wolfgang Langguth	HTW	wlang@htw-saarland.de
Jonathan Manson	Gorham & Partners	jonathanm@gorham.org
Prof Henryk Markiewicz	Wroclaw University of Technology	henryk.markiewicz@pwr.wroc.pl
Carlo Masetti	CEI	masetti@ceiuni.it
Mark McGranaghan	EPRI Solutions	mmcgranaghan@eprisolutions.com
Dr Jovica Milanovic	The University of Manchester	jovica.milanovic@manchester.ac.uk
Dr Miles Redfern	University of Bath	eesmar@bath.ac.uk
Dr ir Tom Sels	KU Leuven	tom.sels@esat.kuleuven.ac.be
Prof Dr-Ing Zbigniew Styczynski	Universität Magdeburg	Sty@E-Technik.Uni-Magdeburg.de
Andreas Sumper	CITCEA-UPC	sumper@citcea.upc.edu
Roman Targosz	PCPC	cem@miedz.org.pl
Dr Ahmed Zobaa	Cairo University	azmailinglist@link.net



Laborelec  
Rodestraat 125  
B-1630 Linkebeek  
Belgium

Tel: 00 32 2 3820503  
Fax: 00 32 2 3820241  
Email: marcel.didden@laborelec.com  
Website: www.laborelec.com

*Dr ir Marcel Didden*

## **Copper Development Association**

Copper Development Association  
5 Grovelands Business Centre  
Boundary Way  
Hemel Hempstead  
HP2 7TE

Tel: 00 44 1442 275700  
Fax: 00 44 1442 275716  
Email: helpline@copperdev.co.uk  
Websites: www.cda.org.uk and www.brass.org



European Copper Institute  
168 Avenue de Tervueren  
B-1150 Brussels  
Belgium

Tel: 00 32 2 777 70 70  
Fax: 00 32 2 777 70 79  
Email: eci@eurocopper.org  
Website: www.eurocopper.org