

Hot Stampings in Copper Alloys

CDA Publication 103, 1994

Hot Stampings in Copper Alloys

CDA Publication 103

September 1994

(Replaces Technical Note TN18, published 1974)

Members as at 1st January 1994

ASARCO Inc
Boliden MKM Ltd
Thomas Bolton Ltd
Brandeis Ltd
The British Non-Ferrous Metals Federation
Chile Copper Ltd
Falconbridge Ltd
Gecamines Commerciale
IMI plc
Inco Europe Ltd
Noranda Sales Corporation of Canada Ltd
Palabora Mining Co Ltd
RTZ Ltd
Southern Peru Copper Corporation

Acknowledgements

This publication has been financed by a group of the leading hot stamping manufacturers in the UK (Bailey Gill Products Ltd, Flowflex Components Ltd, Guests Brass Stamping Co Ltd, Leslie & Co (Coventry) Ltd, NT Peerless Ltd, Rainsford & Lynes Ltd and H E Rudge & Co Ltd) and the International Copper Association. Much of the text has been supplied by the Copper Development Association of South Africa and was published in their booklet 'Brass and Copper Hot Stampings', October 1992.

Copper Development Association

Copper Development Association is a non-trading organisation sponsored by the copper producers and fabricators to encourage the use of copper and copper alloys and to promote their correct and efficient application. Its services, which include the provision of technical advice and information, are available to those interested in the utilisation of copper in all its aspects. The Association also provides a link between research and user industries and maintains close contact with other copper development associations throughout the world.

Website: www.copperinfo.co.uk

Email: helpline@copperdev.co.uk

Copyright: All information in this document is the copyright of Copper Development Association

Disclaimer: Whilst this document has been prepared with care, Copper Development Association can give no warranty regarding the contents and shall not be liable for any direct, indirect or consequential loss arising out of its use

Contents

What is a hot stamping?	2
Why choose hot stampings?	2
Why choose copper alloys?	2
Properties of hot stampings	3
Production of hot stampings	5
Raw materials	5
Billet heating	5
Hot stamping.....	5
Clipping.....	5
Cleaning.....	5
Machining.....	6
Inspection and testing.....	6
Die configurations	7
Open die stamping	7
Closed die stamping.....	7
Multi-cored stamping.....	7
Design of hot stampings	9
Tolerances	9
Shrinkage.....	9
Parting line.....	9
Shape of the cross-section	9
Draft angle	10
Machining allowances	10
Flatness.....	10
Concentricity	10
Web thickness.....	10
Fillets and radii.....	10
Flash thickness.....	10
Identification marks	10
Datum points for machining	10
Applications	11
Plumbing.....	11
Builders hardware.....	11
Transportation	11
Gas welding equipment	11
Refrigeration equipment	12
Fluid handling equipment	12
Electrical equipment.....	12
Fire protection fittings	12
Other applications.....	12
The metallurgy of brass stampings	13
Alloy Selection	2

What is a hot stamping?

A hot stamping is a metal component manufactured by forming a hot, solid billet of material between two halves of a die. The die is so designed as to produce a component which is as close in size to the finished desired product as possible with a minimum of machining and surface finishing necessary. Having produced the die tooling, the stamping process enables accurate and consistent reproduction of the component in batches of from 500 to 50,000 units.

Why choose hot stampings?

Because hot stamping produces high quality, strong, sound components cost-effectively, requiring minimal finishing.

Why choose copper alloys?

Because they are corrosion resistant and easily machined. They are strong, versatile and more reliable than alternative materials.

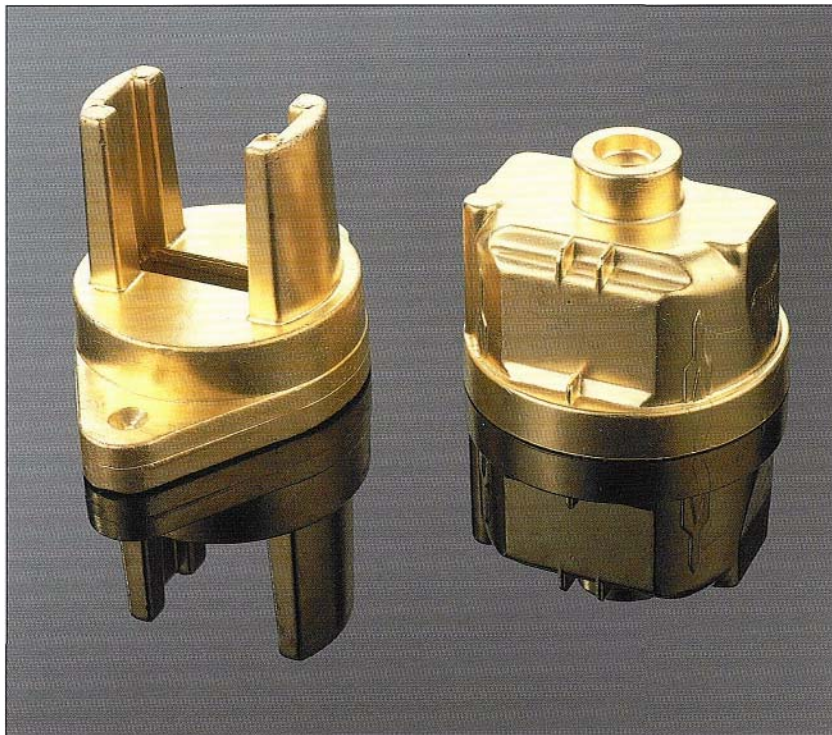

Properties of hot stampings

Copper and copper alloy stampings offer designers and specifiers unique combinations of material and component properties that are unmatched by other materials and manufacturing processes currently available.

- High strength
- Freedom from porosity
- Near-net-shape
- Close, consistent component tolerances
- Superior surface finish
- Optimised metal usage

Added to these are the inherent attributes of copper and its alloys:

- High electrical and thermal conductivity
- Excellent corrosion resistance
- Hot and cold formability
- Excellent machinability
- Excellent joining properties
- Ease of polishing, plating and finishing
- Low magnetic permeability
- Spark resistance
- Good wear resistance
- Aesthetic appeal
- Attractive and versatile solid colours (i.e. not just on the surface)
- Low stamping temperatures giving good die life

The control and combination of these physical and mechanical properties result in quality products giving high integrity, long service life and excellent reliability; all at low overall unit cost.

To produce a finished component there are normally alternative methods which can be utilised. The choices could be for example: machining from a solid, sand casting, die casting, pressure die casting, investment casting or stamping. The final choice will ultimately be based on economics in terms of volumes required and product integrity, and on the availability of suppliers of the various techniques.

The factors which should be borne in mind include:

Hot stamped metal has a fine grain structure which results in mechanical properties superior to those of cast metal so that in many instances thinner sections can be used.

- 1) For hot stamping, precise control can be exercised over the quantity of material used. Material wastage is minimal.
- 2) Scrap rates are minimised by using stampings, there being no risk of casting porosity or entrapment of sand or drosses.
- 3) The absence of dross, or entrapped moulding materials in the surface means that wear on machine tools is minimal.
- 4) Jigs are simplified because stampings are consistent to close tolerances throughout the life of a stamping die set. Hot stampings are excellent for automatic machining stations.
- 5) Finishing costs of polishing and plating are minimised due to the smooth consistent surface imparted by the stamping process.
- 6) Stamping dies have a considerably long life than die casting dies due to the lower temperatures involved. Generally stamping dies will produce up to 50,000 components compared with a maximum of 15,000 shots for die castings.
- 7) Stamping temperatures for copper alloys are much lower than for ferrous materials. The actual temperature depends on the composition of the alloy but will lie within the range 625-975°C.
- 8) The small amounts of swarf generated by machining copper alloys are readily recycled and that generated from stampings generally sells at a higher price than that from castings due to the higher grade of alloy used.



Production of hot stampings

Size Ranges

The minimum and maximum size and mass of hot stampings is largely governed by the capacity of the manufacturing equipment available. Typically they are produced in the range of between 0.1kg and 5kg but these are by no means the limits of possibility. For more information to suit your specific needs, contact the hot stamping manufacturers.

Raw materials

The metal forms used for hot stampings may be castings, extruded rods or extruded sections. The extruded forms are generally preferred because the double hot working ensures a fine-grained, porosity-free metal structure with excellent mechanical properties.

The metal form cut to precise tolerances on size and mass is usually called a billet or 'slug'. Billets should be clean and free from burrs to prevent surface imperfections on the finished product.

Billet heating

The billets are carefully heated to the correct stamping temperature (depending on the alloy) in gas or electric furnaces or by induction heaters. Close control of temperature ensures consistency of the finished product.

Hot stamping

The preheated billet is then placed between two metal dies whose internal cavity is the component shape required. The top die or ram is then powered down forcing the billet to flow and fill the die cavity when the two die halves meet. Several die tooling configurations are discussed in the following section.

Clipping

In order to ensure that the metal completely fills the die cavity, a controlled excess of metal is included in the billet mass which results in 'flash' at the die parting line. This excess is clipped or trimmed off using suitably designed tools. Thin webs left in hollow stampings may also be punched out at this stage.

Cleaning

The next process is to clean the stampings to remove lubricants and surface oxides. Most stampings are bright acid dipped, tumbled with an abrasive medium, or shot blasted.

Machining

Whilst a minimum of machining is required with hot stamping because the components are produced near-to-net-shape, most engineering components do require some machining. Such operations as drilling, tapping, milling and threading are routinely undertaken. Many hot stamping manufacturers are able to finish-machine in-house. Copper alloys, particularly those containing lead are easily machined to close tolerances with a good surface finish and little tool wear. Clean swarf commands a good price because it is readily recycled and this helps to keep the overall costs low.

Inspection and testing

Flaws in stampings are rare and normally visual examination is considered satisfactory. However, in some circumstances it may be necessary to use dye penetrant or even more sophisticated test techniques such as eddy-current, ultrasonic or X-ray inspection.

Hot stampings, as manufactured, are not normally prone to stress corrosion cracking because they do not contain residual stresses. However, in certain environmental service conditions stress relieving may be advisable, normally $\frac{1}{2}$ to 1 hour at 270° to 300°C is appropriate. The efficacy of this heat treatment may be checked by a standard mercurous nitrate test as defined in BS2872 and in the new CEN document EN20196. This test must be used with care because of the health hazards associated with the use of mercury salts. Other tests using ammonia vapour have been evaluated but are not yet fully accepted because the results are not as clearly defined as those given by the mercurous test.



Die configurations

There are essentially three die configurations in common use. The choice of configuration used is left to the manufacturer to use his wide experience and state-of-the-art technical skills to optimise metal usage, die life and ultimately the finished component cost.

Open die stamping

This is the least complex die arrangement whereby when the die halves are forced together, metal flow is initiated before the die halves meet, and completed once the die halves are in face to face contact or a pre-set register position. See Figure 1a.

Closed die stamping

In this configuration the two die halves initially close face to face around the hot billet and are then forced down onto a third die part or core pin which causes the metal to fill the die cavity. See Figure 1b.

Multi-cored stamping

Again using a closed die configuration but here two, three or four cores at 90° to each other are arranged along the parting line. The powered entry of the cores into the die causes the billet to fill the die cavity resulting in a stamping with two, three or four hollow intrusions into the body of the metal. See Figure 1c.

The use of closed die stamping techniques allows for deeper and more accurate coring resulting in less metal usage, reduced machining time, higher production rates and hence a more cost-effective product. The extraction methods employed in closed die techniques often allow for more complex external and internal features in the component to be accommodated.

Figure 1a

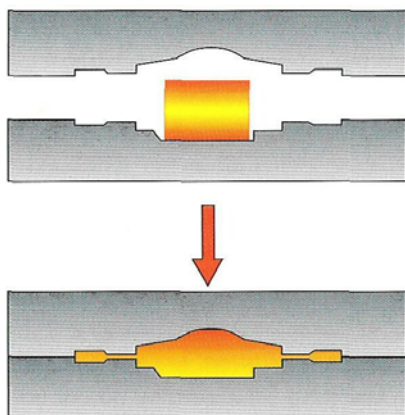

Figure 1b

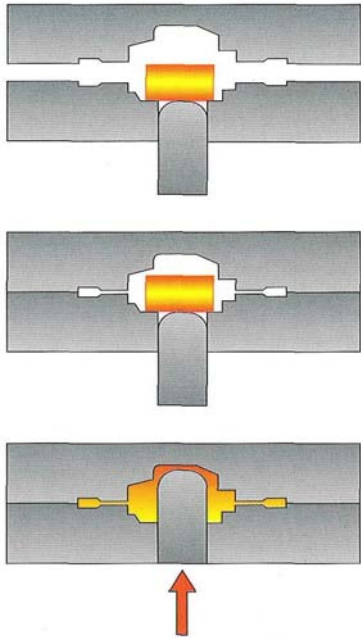
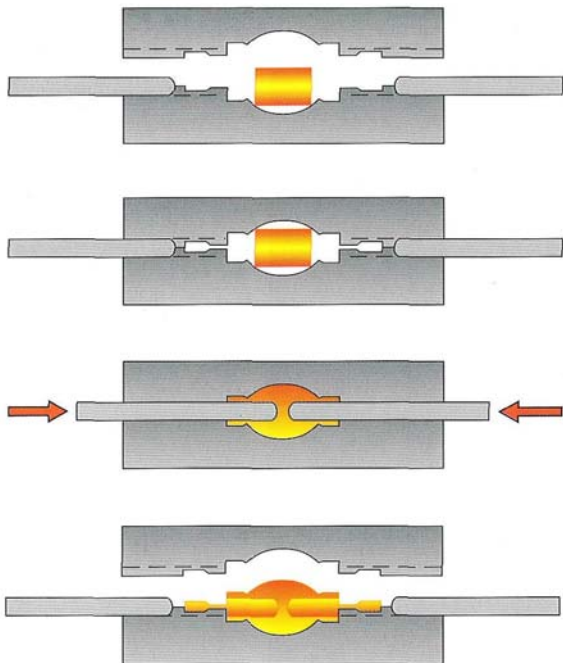

Figure 1c



Design of hot stampings

The design of hot stampings is best undertaken after liaison with experienced, skilled manufacturers. The illustrations of hot stamped components in this publication give an indication of the scope of the process but are by no means exhaustive. Contact manufacturers and they will gladly discuss your requirements in detail and advise the optimum design and process to suit component volumes, tolerances and cost.

To further enhance the benefits and cost-effectiveness of hot stampings, CAD/CAM techniques are being used by modern stamping shops. See *Figure 2* below.

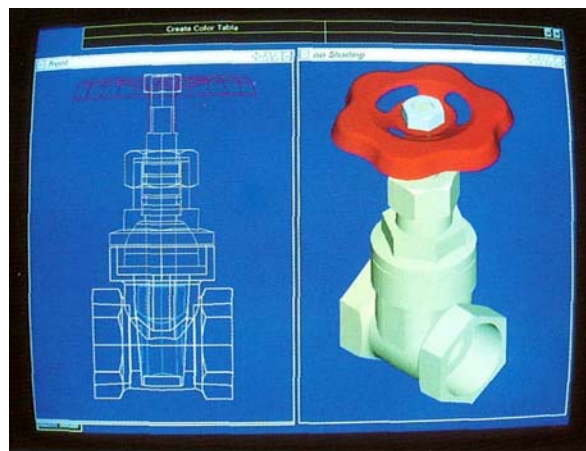

As a general guideline the following points have to be considered when designing a hot stamping:

Tolerances

BS 3885 defines the tolerances for hot brass stampings. The figures given below are for guidance only.

Shrinkage

Allowance must be made in the tooling for the shrinkage that occurs when the stamping cools from hot working temperature to ambient temperature. This allowance will vary with the shape and size of the component but as a general rule about 1% is added.

Parting line

It is desirable for the parting line to be horizontal and in one place, and for the cavities on the two halves to have nearly equal volumes.

Shape of the cross-section

The simplest cross-section to produce is a circle but other shapes can be achieved. Abrupt changes in section lead to heavily stressed dies as well as large shrinkage stresses in the stamping and should be avoided.

Draft angle

The removal of a stamping from the dies is facilitated by sloping the sides of the die. This is called the draft, or draft angle, and may vary between 0° and 5° .

Machining allowances

Where required, the machining allowance on any one surface should be of the order of 0.8mm, increasing with size of the stamping.

Flatness

BS 3885 gives a flatness tolerance of 0.014 in (0.35mm) per 2 ½ in (63.5mm) length.

Concentricity

The concentricity of like-shaped features having a common centre will vary largely with the process technique used and should be assessed for each component.

Web thickness

A web is a thin metal section attached to one or more heavy sections. The nominal minimum web thickness varies with the alloy being used, but for hot stamping brass it would be about 3mm and for the harder materials about 5mm.

Fillets and radii

Fillets and radii should not be too small as these lead to reduced die life due to wear and thereby increased component cost. The minimum fillet radius is generally about 0.75mm to 1.5mm with a tolerance of +0.4mm.

Flash thickness

The relief cavity around the die parting line to accommodate excess billet material will be determined by the die designer but will typically be in the range 0.75mm for hot stamping brass and 1.5mm for harder materials.

Identification marks

Stampings frequently need to be identifiable by means of letters or numbers. These may be recessed into an interchangeable insert in the die so that the markings are at right angles to the die motion.

Datum points for machining

Since die wear is greatest near the parting line, locating points for machining should be kept away from it. The centres of holes to be drilled subsequently may be spotted or indented if the axes of the holes are parallel to the die motion.

Applications

Copper and copper alloy hot stampings are used in virtually all industries but some of the major uses are listed below.



Plumbing

Taps, control valves, pressure valves, pipe unions and fittings, nuts, bath and basic wastes, strainers, shower heads, pump parts and electric immersion heater element bosses.

Builders hardware

Door knockers, handles and face plates, lock bodies and barrels, window handles and fittings, eyebolts, wingnuts, brass bed and handrail fittings.

Transportation

Piston guide bushings and valve plugs, air brake servo-pistons, automotive gear rings, control equipment linkages and hydraulic fluid line fittings.

Gas welding equipment

Torch components, jets, 'Y' fitting assemblies, control valves, regulator bodies and associated components.

Refrigeration equipment

Manifolds, filter parts, liquid indicators and all types of valves; shut off, regulator, thermostatic, pressure control and relief valves.

Fluid handling equipment

Impellers, gas and oil couplings, parts for fuel pumps etc.

Electrical equipment

Selector contacts and switchgear accessories and the blades, washers and retaining caps for uses.

Fire protection fittings

Fire hose couplings, water control valves and fog nozzles. Also line and outlet fittings in fixed fire sprinkler systems.

Other applications

As diverse as ordinance components, medical equipment, golf clubs, gear housings, supports, brackets, worm gears and pressure gauge bodies.

The metallurgy of brass stampings

Stamping is performed hot in order to minimise the mechanical power required to cause plastic deformation of the metal into the desired shape. The properties of brasses can be controlled to optimise the ease of hot working and maintain good mechanical properties at room temperature. This is achieved by selecting particular alloy compositions and carefully controlling impurity levels.

In order to understand the behaviour of an alloy it is necessary to be aware of the equilibrium diagram which is a graphic representation of how the metal phases change with variations in temperature and composition. This is shown in Figure 3 for the binary copper-zinc system. The two phases represented are called α (alpha) and β (beta). Alpha is a copper-rich phase which is very ductile at ambient temperatures and only reasonably plastic at elevated temperatures. Beta is a zinc-rich phase which is hard and brittle at ambient temperature but extremely plastic at elevated temperatures.

Figure 3

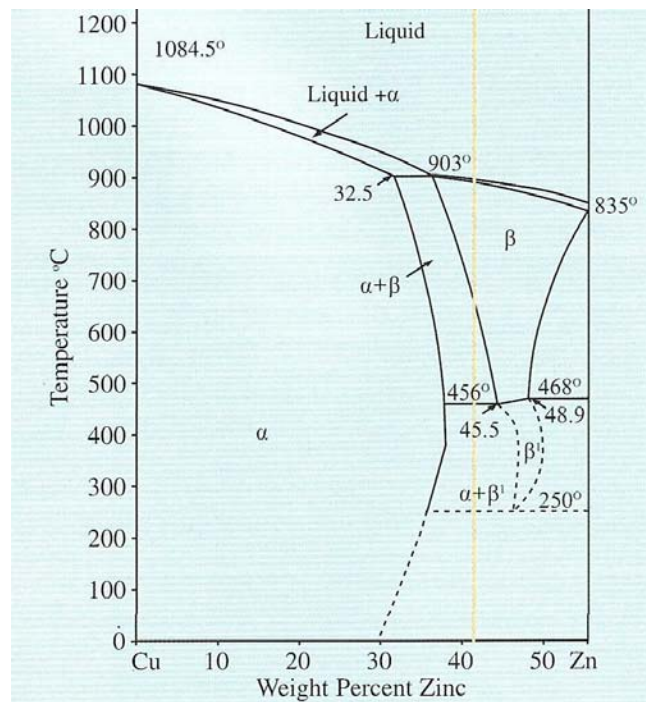

The metal required for a hot stamping should have strength and reasonable ductility at ambient temperature (a mixture of alpha and beta) and be very plastic at elevated temperatures (a beta rich structure >50% beta). From Figure 3 it can be seen that a composition of about 60% copper, 40% zinc suits this combination of requirements, and all the most popular hot stamping brasses have approximately this proportion of zinc and copper with other alloying elements which confer other properties. The presence of other alloying elements does, however, alter the equilibrium diagram and changes the proportions of alpha and beta phases present at different temperatures. Each alloying element has a 'zinc equivalent' and these are listed in Table 1. In order to predict the behaviour of the alloy under hot stamping it is necessary to calculate the effective copper content of the alloy which can be done by using the following formula:

$$\text{Effective Cu\%(E)} = \text{Actual Cu\% (A)} \frac{100}{100 + X(k - 1)}$$

Where $X = \% \text{ alloy addition}$
 $k = \text{zinc equivalent of the addition}$

The proportions of alpha and beta at the temperature of interest can then be read from Figure 3. The most commonly used alloy for hot stamping is CZ122 which has a nominal composition of:

Cu 58% Pb 2% Zn 40%

The lead addition improves the machinability of the alloy because it exists as discrete particle in the brass matrix and acts as a chip-breaker during machining. (At the temperature of hot working when the alloy is in the beta phase no embrittlement occurs because the lead is soluble in the beta phase up to about 2%).

Table 1 – Zinc equivalents of elements (k)

Ni - -1.2	Sn – 2.0
Pb – 1.0	Al – 6.0
Mn – 0.5	Si – 10.0
Fe – 0.9	Mg – 2.0

From Table 1 the zinc equivalent of lead is 1 so that the effective copper content is equal to the actual copper content, and the proportions of alpha and beta at the temperature of interest can be read from Figure 3.

Figure 4

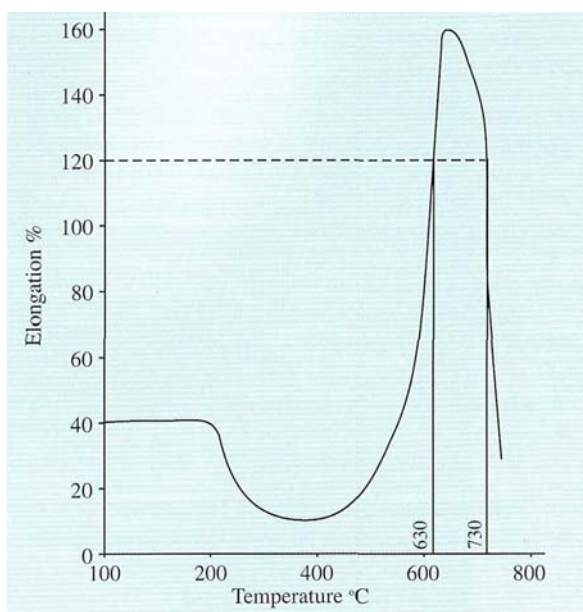

Figure 4 shows how the elongation of this alloy varies with temperature, and that a minimum elongation of 120% is achieved in the temperature range 630-730°C. This is ideal for hot stamping production.

Alloy Selection

The choice of alloy to be used is dependent on the end use of the component. The selection is influenced by such factors as the required strength, corrosion resistance, and the need for machining. These requirements should first be discussed with the hot stamping manufacturers. Different alloys will permit differing degrees of hot ductility which in turn will affect the complexity of the component which can be produced and the die life of the hot stamping tooling. Component design is best discussed with the manufacturer as early as possible in the development cycle in order to optimise the design both for performance and ease of production.



Brasses are by far the most popular alloys for hot stamping because of their excellent hot working properties and good machinability combined with high strength and corrosion resistance. A number of different brasses are readily available for stamping covering a variety of properties suitable for particular applications. Stampings can also be made successfully in copper and other copper alloys including nickel silvers, aluminium bronzes and copper-nickel alloys, but in the UK the only commonly used materials besides brass are high conductivity copper and aluminium bronzes. Table 3 lists the compositions and typical mechanical properties of the alloys most commonly used in the UK.

The present British Standards are soon to be replaced by the new European Standards. These are being agreed by all member countries and will be adopted without modification by the standards body in each country. All of the commonly used British hot stamping alloys will have near equivalents in the new standard and there will also be many more alloys specified. A complete list of the proposed alloys is given in Table 2, grouped, as they will be in the standard, according to the ease with which they can be hot worked and to their availability.

In almost all cases the European alloys differ slightly from the British ones and, in order to aid users of the new standards, Table 3 lists the compositions and properties of the near-equivalents for comparison. In a few cases the differences are significant. For example, impurity limits in some alloys will be higher, and this will affect machinability. However, provided that alloys are chosen with care, the new alloys can be specified with confidence.

Table 2 – Materials to be included in the CEN standard for copper and copper alloy forgings

Generally Available			Available to Special Order		
CEN Alloy Designation	CEN Material Number	Nearest BS Equivalent	CEN Alloy Designation	CEN Material Number	Nearest BS Equivalent
These materials are very readily hot worked:					
CuZn40	CW509L	CZ109	CuZn37	CW508L	CZ108
CuZn38Pb2	CW608N	CZ128	CuZn38Pb1Sn1	CW712R	-
CuZn39Pb2	CW612N	CZ120	CuZn39Sn1	CW719R	CZ133
CuZn39Pb3	CW614N	CZ121-Pb3	CuZn39Pb0.5	CW610N	CZ137
CuZn40Pb2	CW617N	CZ122	CuZn39Pb1	CW611N	CZ129
CuZn39Pb2Sn	CW613N	-	CuZn23Al6Mn4Fe3Pb	CW704R	-
CuZn40Pb1Al	CW616N	-	CuZn35Mn2Ni2Al1Pb	CW710R	-
CuZn40Pb2Sn	CW619N	-	CuZn40Mn1Pb1	CW720R	CZ136
CuZn36Pb2As	CW602N	CZ132	CuZn40Mn2Fe1	CW723R	-
CuZn37Mn3Al2PbSi	CW713R	CZ135			
CuZn37Pb1Sn1	CW714R	-			
CuZn38Al1Mn1PbSi	CW718R	-			
CuZn40Mn1Pb1Al1FeSn	CW721R	CZ114			
CuZn40Mn1Pb1FeSn	CW722R	CZ115			
These materials are less easy to hot work:					
Cu-ETP	CW003A	C101	Cu-HCP	CW021A	-
Cu-OF	CW008A	C103	Cu-DHP	CW024A	C106
CuAl8Fe3	CW303G	CA106	CuAl6Si2Fe	CW301G	-
CuAl10Fe3Mn2	CW306G	CA105	CuAl7Si2	CW302G	CA107
CuAl10Ni5Fe4	CW307G	CA104	CuAl9Ni3Fe2	CW304G	-
CuAl11Fe6Ni6	CW308G	-	CuAl10Fe1	CW305G	-
These materials are also hot workable:					
CuCr1Zr	CW106C	CC102	CuBe2	CW101C	CB101
CuNi2Be	CW110C	-	CuCr1	CW105C	CC101
CuNi2Si	CW111C	-	CuCo1Ni1Be	CW103C	-
CuNi10Fe1Mn	CW352H	CN102	CuCo2Be	CW104C	C112
CuNi30Fe1Mn	CW354H	CN107	CuZr	CW120C	-
			CuNi1Si	CW109C	-
			CuNi3Si	CW112C	-
			CuNi7Zn39Pb3Mn2	CW400J	-
			CuNi10Zn42Pb2	CW402J	NS101

Table 3 – Compositions and properties of the most commonly available British standard hot stamping alloys

MATERIAL	ALLOY DESIGNATION		ATTRIBUTES	COMPOSITION													MINIMUM MECHANICAL PROPERTIES			
	British Standard Designation	Nearest Equivalent CEN Alloy		CEN Alloy Number	Cu	Al	Fe	Ni	Pb	Sn	Mn	Si	As	Zn	Bi	Others Total	Tensile Strength	0.2% Proof Stress	Hardness HV	Elongation %
				min	max	min	max	min	max	min	max	min	max	min	max	min	max	min	max	
Leaded Brass	CZ122	CuZn40Pb2	CW617N	This is the alloy most frequently used for hot stamping. It has good machinability.	min	56.5			1.5					Rem		350			25	
					max	58.5	0.3		2.5						0.7					
					min	57.0			1.6						Rem		360	120	85	20
		CuZn40Pb2Sn†	CW619N		max	59.0	0.05	0.3	0.3	2.5	0.3			Rem		0.2				
min	57.0						1.6	0.2							360	120	85	20		
		max	59.0	0.1	0.4	0.3	2.5	0.5						Rem		0.2				
Lead-Free 60/40 Brass	CZ109	CuZn40	CW509L	This alloy is lead-free and has superior cold ductility as well as excellent hot working properties. It is not so readily machined.	min	59.0								Rem		310			25	
					max	62.0			0.1											
					min	59.5										Rem		340	100	80
		max	61.5	0.05	0.2	0.3	0.3	0.2						Rem		0.2				
High-Speed Machining Brass	CZ121-Pb3	CuZn39Pb3	CW614N	This alloy has excellent machinability.	min	56.5			2.5					Rem		350			25	
					max	58.5	0.3		3.5											
					min	57.0			2.5							Rem		360	120	85
		CuZn39Pb3Sn†	CW615N		max	59.0	0.05	0.3	0.3	3.5	0.3			Rem		0.2				
min	57.0						2.5	0.2								360	120	85	20	
		max	59.0	0.1	0.4	0.3	3.5	0.5						Rem		0.2				
Leaded Brass	CZ128	CuZn38Pb2	CW608N	This alloy has a higher copper content than CZ122 and so has better cold ductility combined with good machinability.	min	58.5			1.5					Rem		350			25	
					max	61.0	0.2		2.5											
					min	60.0			1.6							Rem		360	120	85
		CuZn39Pb2	CW612N		max	61.0	0.05	0.2	0.3	2.5	0.2			Rem		0.2				
min	59.0						1.6									360	120	85	20	
		max	60.0	0.05	0.3	0.3	2.5	0.3						Rem		0.2				
		min	59.0					1.6	0.2					Rem						
		max	60.0	0.1	0.4	0.3	2.5	0.5						Rem		0.2				
Dezincification Resistant Brass	CZ132	CuZn36Pb2As	CW602N	This is used for plumbing fittings in areas where the water supply is aggressive to other brasses. It requires heat treatment to ensure dezincification resistance.	min	Rem			1.7					0.08- 35.0		280			30	
					max				2.8	0.2				0.15	37.0	0.5				
					min	61.0			1.7					0.02- 0.15	Rem		280	90	75	30
		max	63.0	0.05	0.1	0.3	2.8	0.1	0.1											
High Tensile Brass	CZ135	CuZn37Mn3Al2PbSi	CW713R	There is an addition of silicon which imparts excellent wear resistance.	min	57.0	1.0			1.5	0.3			Rem		550	200		15	
					max	60.0	2.0	0.5	0.2	0.8	0.3	3.5	1.3							
					min	57.0			0.2			1.5	0.3			Rem		510	220	150
		max	59.0	1.3	2.3	1.0	0.8	0.4	3.0	1.3										
		min	56.5	0.3			0.5	0.2	0.5				Rem		460	180		15		
		max	58.5	1.5	1.0		1.5	0.8	2.0				Rem		440	180	105	15		
		min	57.0	0.3	0.2		0.8	0.2	0.8				Rem		440	180	105	15		
		max	59.0	1.2	1.2	0.3	1.6	1.0	1.8				Rem		440	180	105	15		
High Tensile Brass Without Aluminium	CZ115	CuZn40Mn1Pb1FeSn	CW722R	The absence of aluminium in this alloy avoids non-wetting problems during soft soldering operations.	min	56.5	0.3		0.5	0.2	0.5			Rem		460	180		15	
					max	58.5	0.1	1.0		1.5	0.8	2.0								
					min	56.5	0.2		0.8	0.2	0.8					Rem		390	150	90
		max	58.5	0.1	1.2	0.3	1.6	1.0	1.8				Rem		390	150	90	20		
Manganese Brass	CZ136	CuZn40Mn1Pb1	CW720R	This has excellent resistance to seizure. It is also used for architectural fittings.	min	56.0				0.5				Rem		350			25	
					max	59.0			3.0	1.5										
					min	57.0			1.0	0.5						Rem		To be agreed between purchaser and supplier		
		max	59.0	0.2	0.3	0.6	2.0	0.3	1.5	0.1										
High Conductivity Copper	C101	Cu-ETP	CW004A	Used for applications requiring high electrical or thermal conductivity.	min	99.90 (inc Ag)										150			20	
					max				0.005											
					min	99.90*										0.0010	0.03 excl O and Ag		200	40
		max					0.005						0.0005	0.03 excl O** and Ag						
Nickel Aluminium Bronze	CA104	CuAl10Ni5Fe4	CW307G	High strength aluminium bronze with excellent corrosion resistance.	min	Rem	8.5	4.0	4.0							700	350		14	
					max		11.0	5.5	5.5	0.05	0.01	0.50	0.2	0.40						
					min	Rem	8.5	3.0	4.0									720	360	150
		max		11.0	5.0	6.0	0.05	0.1	1.0	0.2	0.4									
Silicon Aluminium Bronze	CA107	CuAl6Si2Fe	CW301G	High strength aluminium bronze with excellent corrosion resistance and very low magnetic permeability.	min	Rem	6.0	0.5		2.0						520	220		20	
					max		6.4	0.7	0.10	0.05	0.10	0.10	2.4	0.40						
					min	Rem	6.0	0.5					2.0							
		max		6.4	0.7	0.1	0.005	0.1	0.1	2.4	0.4									

† These alloys have a higher permitted impurity level * incl Ag up to max of 0.015% ** maximum oxygen content 0.040%

Leaded Brass, CZ122

This is the alloy most frequently used for hot stamping.

Lead Free 60/50 Brass, CZ109

This alloy is lead-free and has superior cold ductility as well as excellent hot working properties. It is not so readily machined.

High-speed machining brass, CZ121-Pb3

This alloy has excellent machinability.

Leaded Brass, CZ128

This alloy has a higher copper content than CZ122 and so has better cold ductility combined with good machinability.

Dezincification Resistant Brass, CZ132

This is used for plumbing fittings in areas where the water supply is aggressive to other brasses. It requires heat treatment to ensure dezincification resistance.

High Tensile Brass, CZ135

There is an addition of silicon which imparts excellent wear resistance.

High Tensile Brass, CZ114

There is a lead addition to improve machinability.

High Tensile Brass Without Aluminium, CZ115

The absence of aluminium in this alloy avoids non-wetting problems during soft soldering operations.

Manganese Brass, CZ136

This has excellent resistance to seizure. It is also used for architectural fittings.

High Conductivity Copper, C101

Used for applications requiring high electrical or thermal conductivity.

Nickel Aluminium Bronze, CA 104

High strength aluminium bronze with excellent corrosion resistance.

Silicon Aluminium Bronze, CA 107

High strength aluminium bronze with excellent corrosion resistance and very low magnetic permeability.