

Fig 52a  
Section Long Strip

TRADITIONAL	✓	LONG STRIP	✓
-------------	---	------------	---

\* A recessed pitched valley gutter is the only option with batten rolls because forming the roll end needs a change in level. Also the use of batten roll implies low pitch roofing, and flush pitched valley gutters cannot be used at low pitches.

\* Should the roof pitches draining into the pitched valley gutter be at or over 20degrees, the lining plate can be nailed directly to the substrate without a recess, as shown in Fig 41a (p96).

\* The roll end is formed as shown in Fig 38 (p90), 39 (p92) or 42 (p97).

\* Pitched valley gutters in general are covered with Fig 30 (p77) and Tables P and T (p13).

Temper: soft, quarter- or half-hard in Traditional roofing. Quarter- or half-hard in Long Strip roofing. Pre-formed gutter lining and lining plate; half-hard. Thickness: 0.6mm or 0.7mm

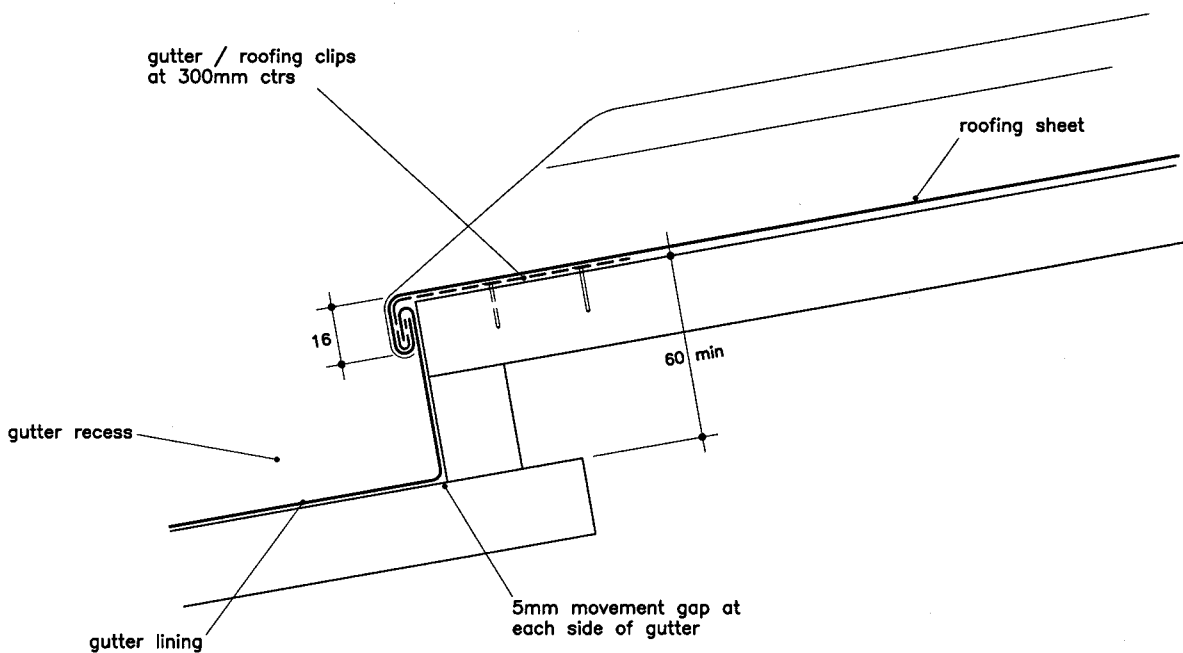

Fig 52b  
Section Traditional

TRADITIONAL	✓	LONG STRIP	X
-------------	---	------------	---