

Fig 5 Chamfer-form seam end

This is sometimes referred to as a 'splayed edge seam end'. The Concave-form and the Square-form seam ends (see Figs 4 and 6) are alternatives. It can be used to end angle standing seams in roofing. Also to end double-lock standing seams or angle standing seams in cladding.

The detail on its own is not weathertight. It also needs an eaves strip or lining plate underneath it, extending 130mm minimum up the roof slope (see Figs 26 and 28). This is shown on the preceding details (see Figs 4a, 4b, 4c, 4d, 4e and 4f). Joints in eaves strips or lining plates are either 150mm lapped joints or, more usually and preferably, 50mm lapped and sealed. They must be positioned at least 150mm from standing seams, but a convenient rule is to make such joints mid-bay.

The eaves strip or lining plate should project sufficiently, so that the turn-under of the roofing sheet can engage it by 20mm and still have 10mm for movement. In Traditional roofing the 10mm movement gap is not required. In effect, in Long Strip roofing the roofing sheets are cut 40mm beyond the end of the eaves strip; and in Traditional roofing 20mm beyond.

Temper: half-hard preferably, although it does take more working at Stage 3 than softer copper.
 Thickness: 0.6mm or 0.7mm

TRADITIONAL ✓ LONG STRIP ✓

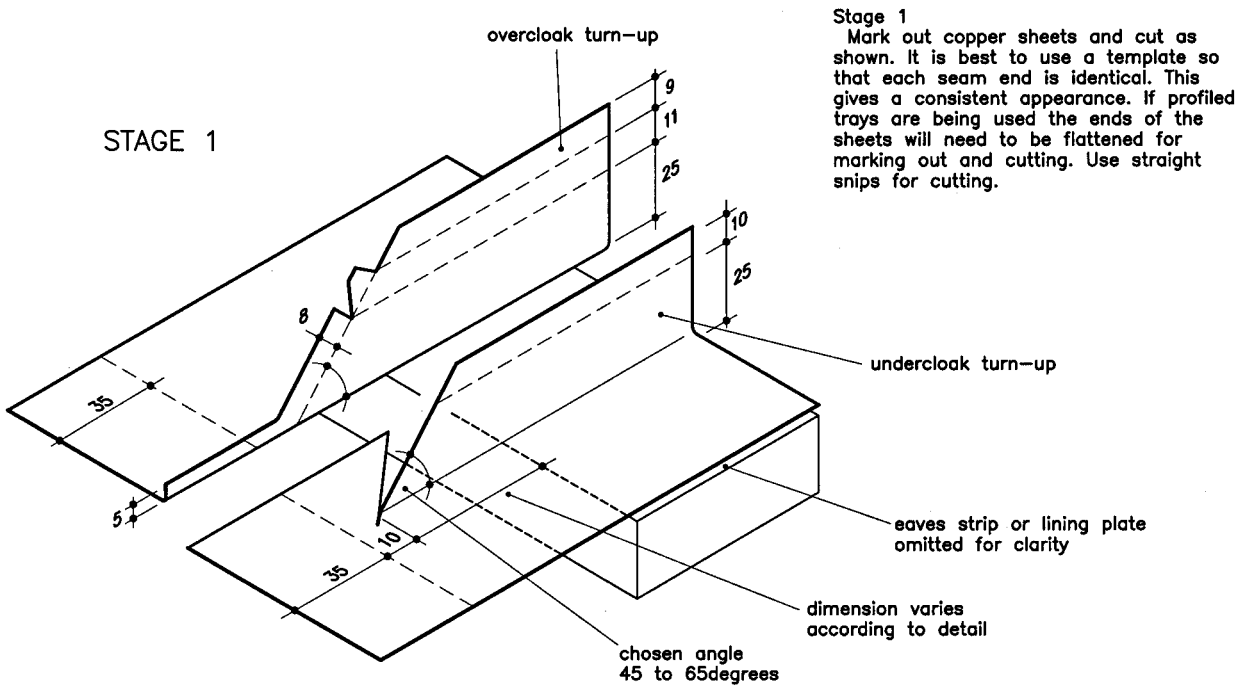

Stage 1
 Mark out copper sheets and cut as shown. It is best to use a template so that each seam end is identical. This gives a consistent appearance. If profiled trays are being used the ends of the sheets will need to be flattened for marking out and cutting. Use straight snips for cutting.

STAGE 1

Stage 2
 Bring copper sheets together.

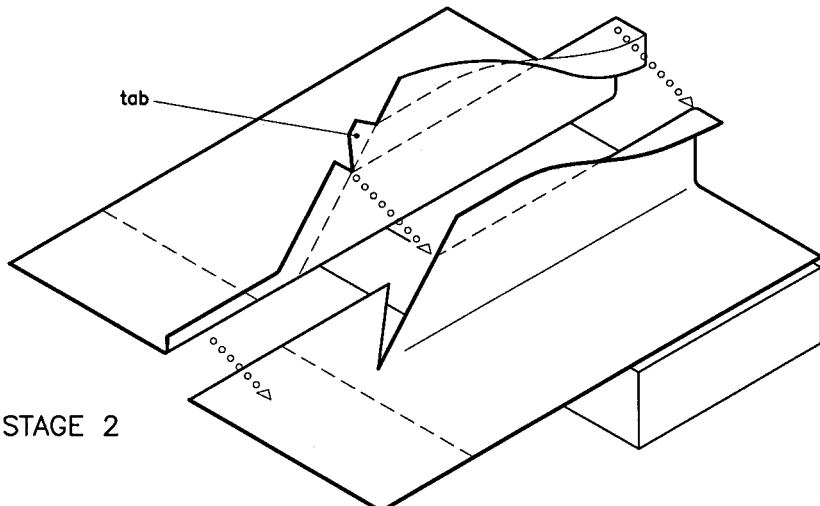

STAGE 2

Stage 4

Fold the standing seam copper over to regain the shape of the profiled tray, flattened out for Stage 1. Then fold the 9mm turn-down of the overcloak around the 10mm turn-out of the undercloak using cranked seaming pliers.

STAGE 4

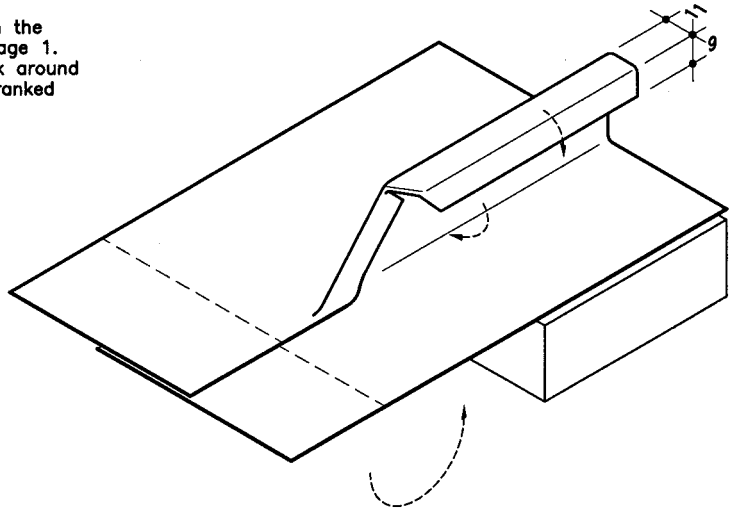

STAGE 3

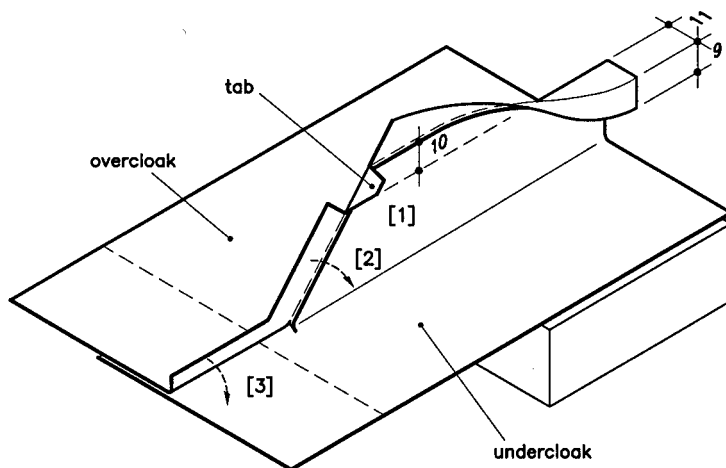
**Stage 3**

Tuck the tab [1] at the top of the seam around the end of the undercloak. Work overcloak at the chamfer over undercloak [2] using a small mallet. The overcloak is then flattened back against the undercloak [3] which is supported by a seaming iron.

STAGE 5

Stage 5

Dress seam down to complete the joint. Then fold the ends, now united, of the copper sheets around the projecting eaves strip or lining plate, according to detail. This will have been nailed in place beforehand. Eaves folders ('first and second turn') should be used. In Long Strip roofing a 10mm gap is left for movement.

