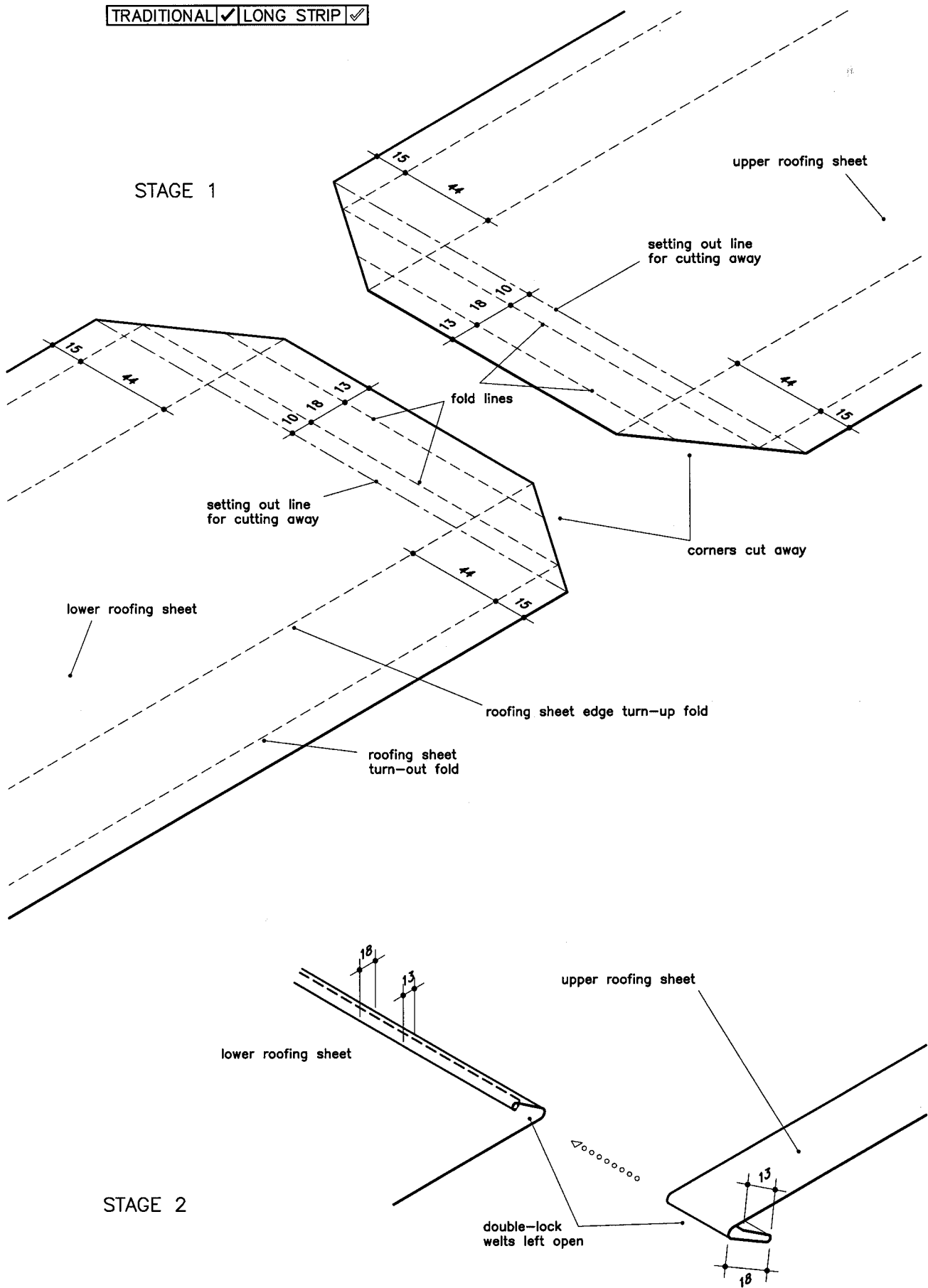
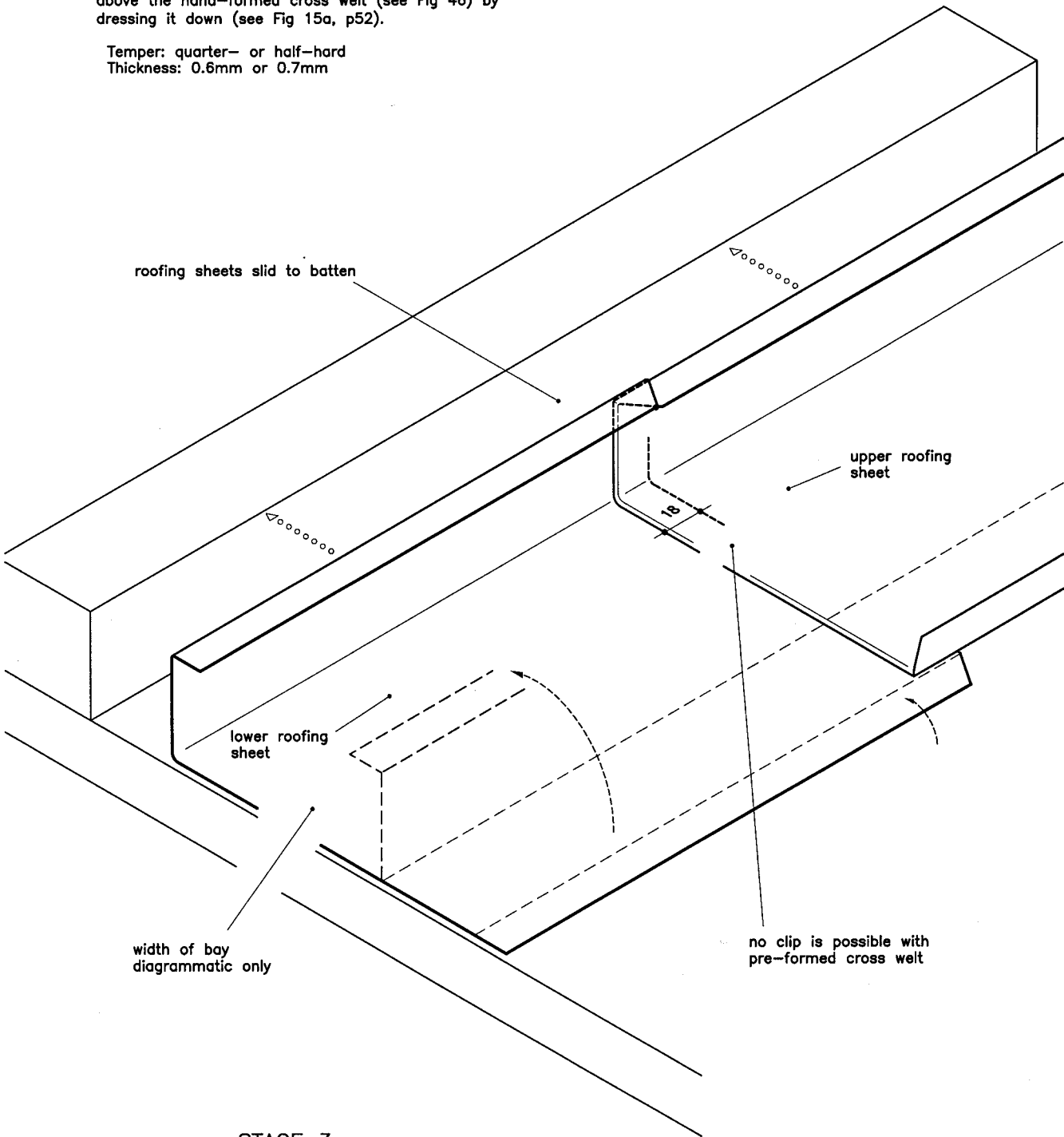

Fig 47 Batten roll junction with pre-formed double-lock cross welt



* This method avoids the crease formed immediately above the hand-formed cross welt (see Fig 46) by dressing it down (see Fig 15a, p52).

Temper: quarter- or half-hard
Thickness: 0.6mm or 0.7mm



STAGE 3