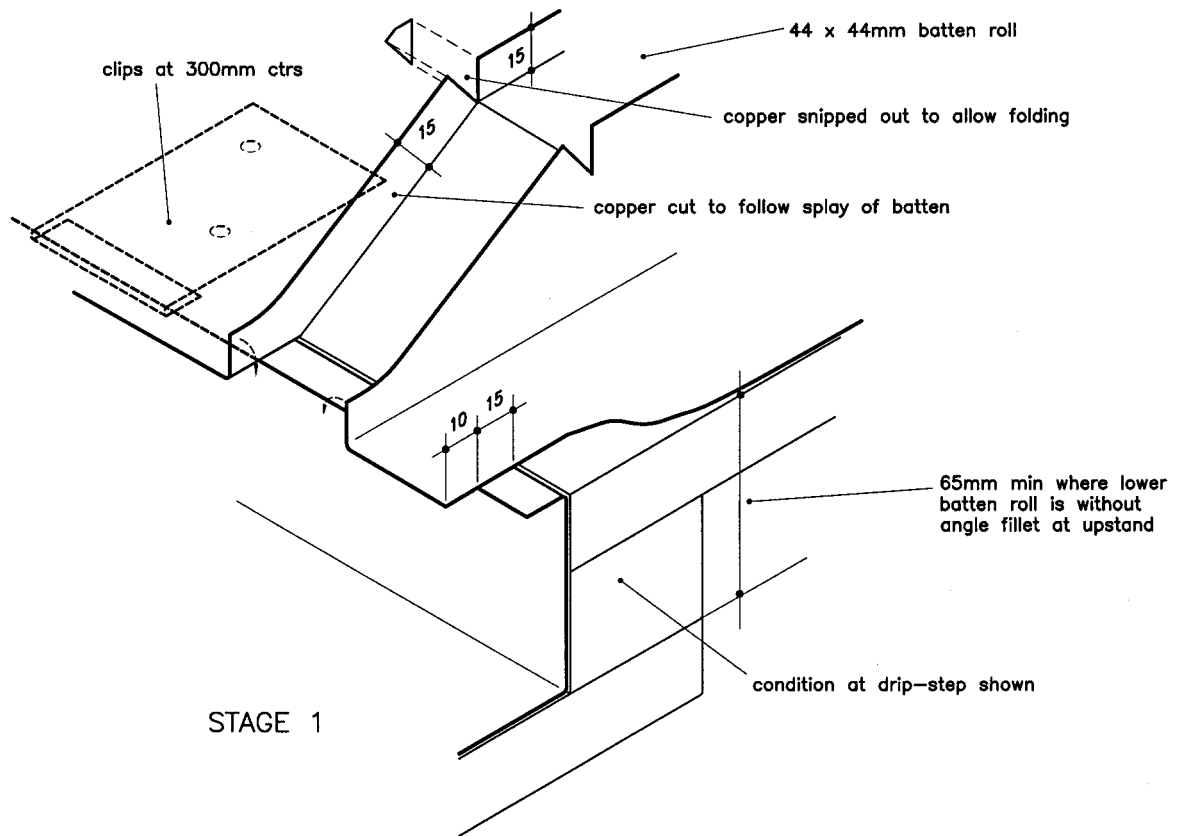

Fig 42 Splayed batten roll end with separate end capping

TRADITIONAL LONG STRIP



STAGE 1

* This detail shows the usual method of finishing a batten roll end in Traditional roofing. Those shown in Figs 38 and 39 are alternatives, with the difference that the 10mm movement gap shown in those figures is not required.

Temper: soft or quarter-hard
Thickness: 0.6mm or 0.7mm

[1] copper dressed over splay

[2] copper dressed down follow line of batten

STAGE 2

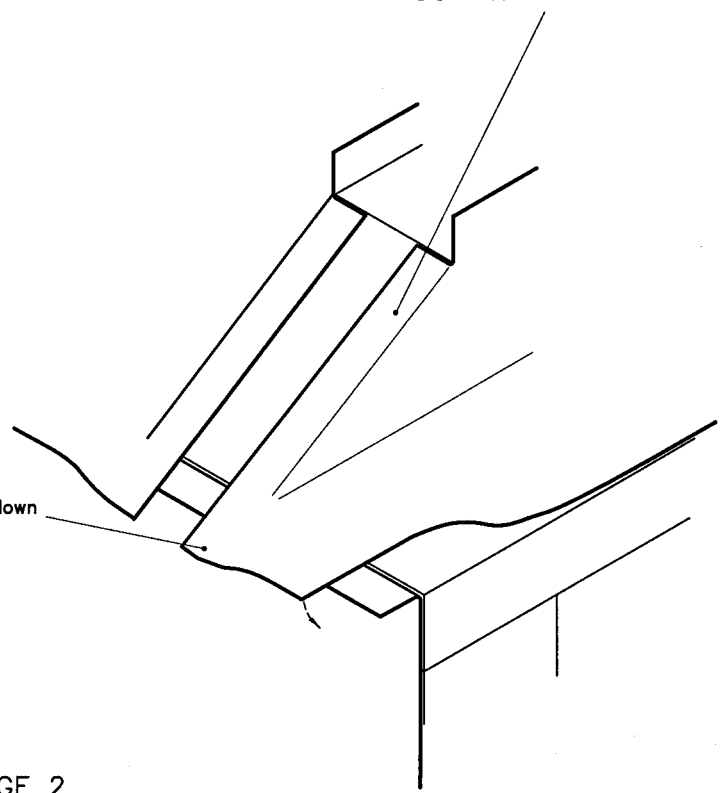
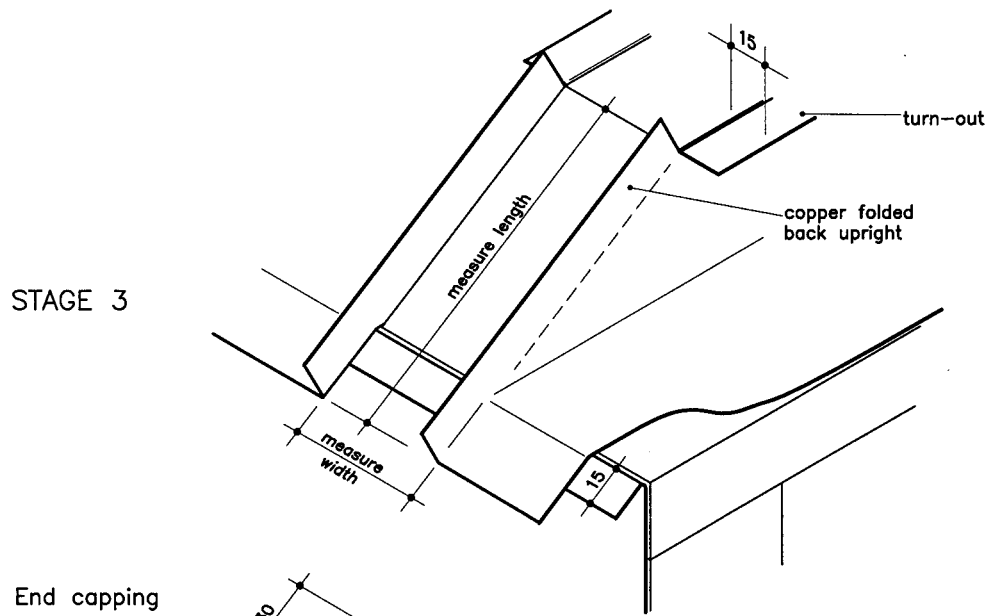
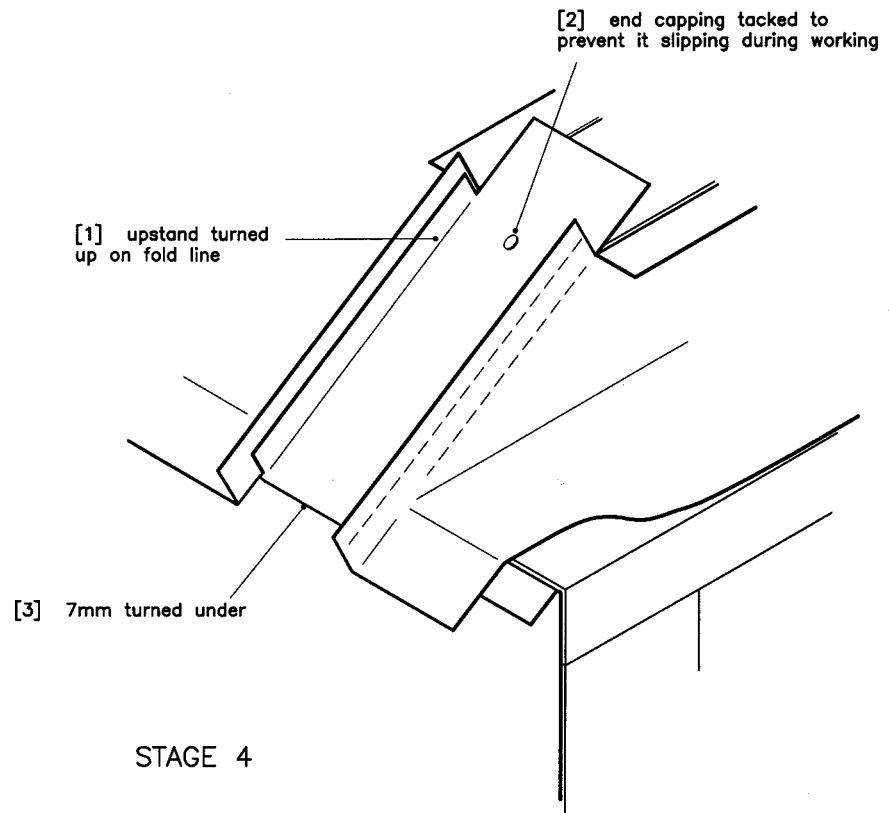
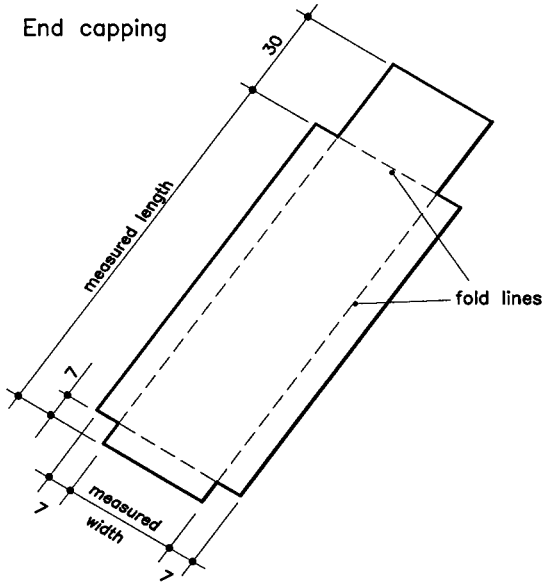

Fig 42 Splayed batten roll end with separate end capping



End capping



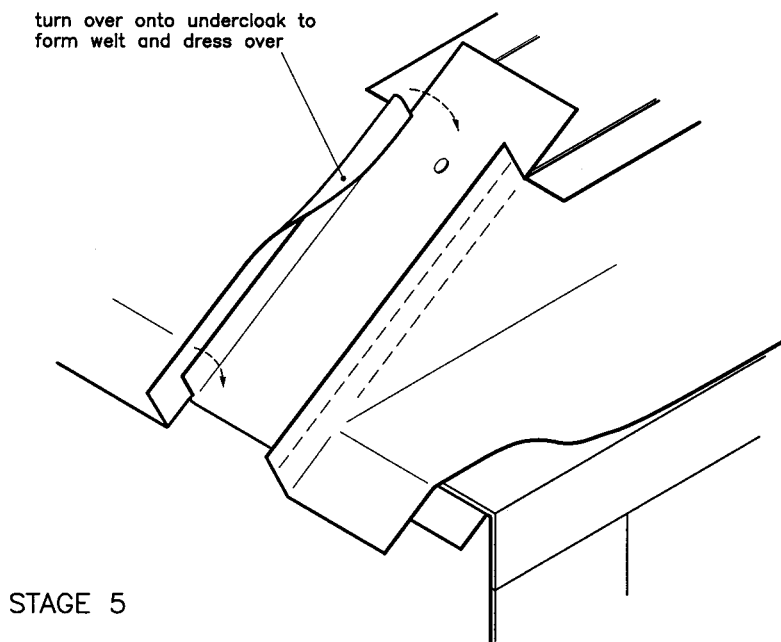
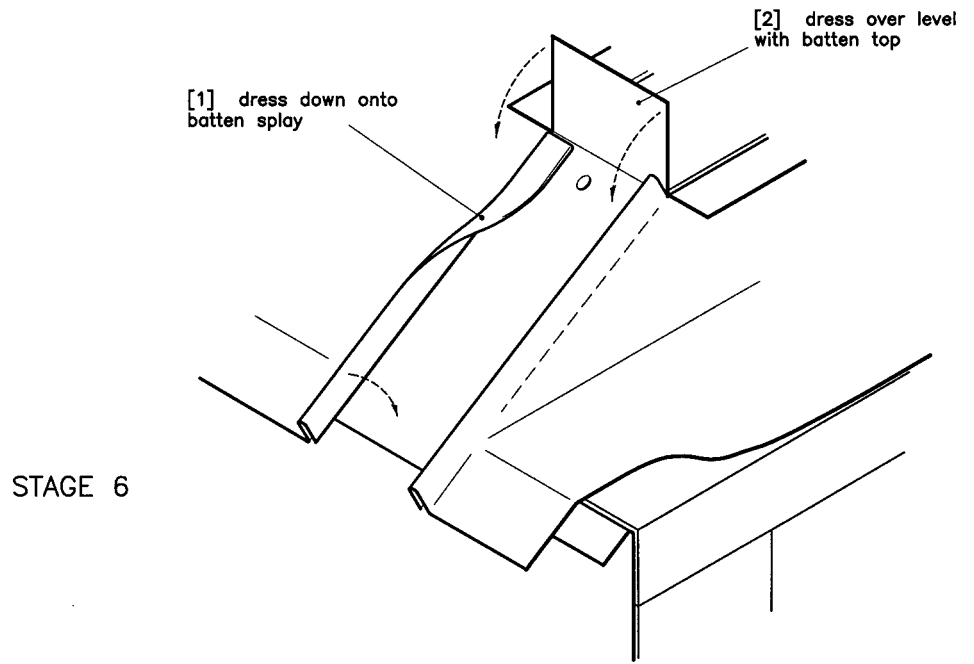
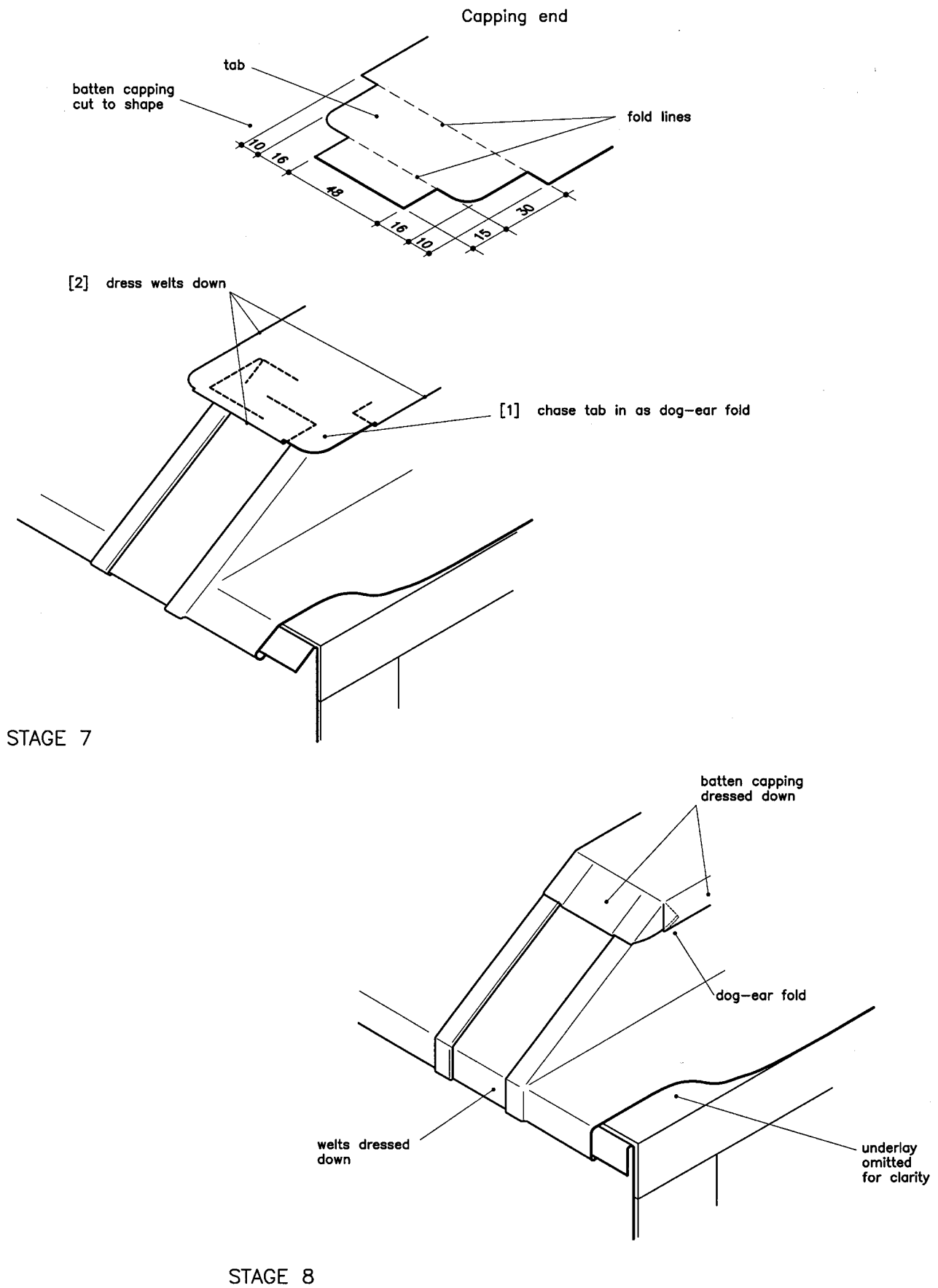

Fig 42 Splayed batten roll end with separate end capping



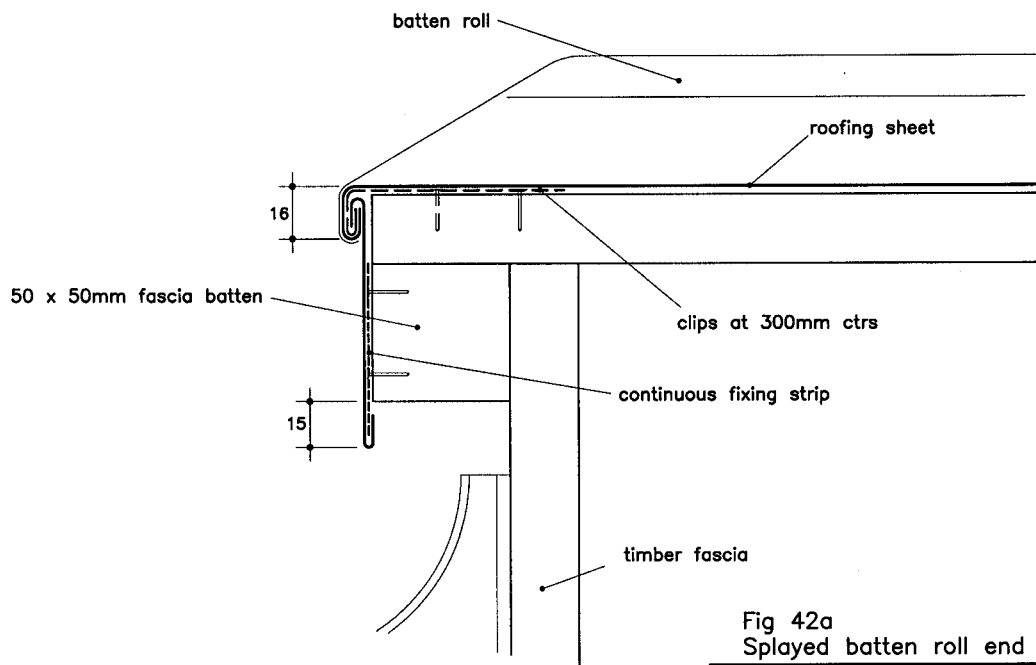

Fig 42a
Splayed batten roll end at timber fascia
TRADITIONAL ✓ LONG STRIP X

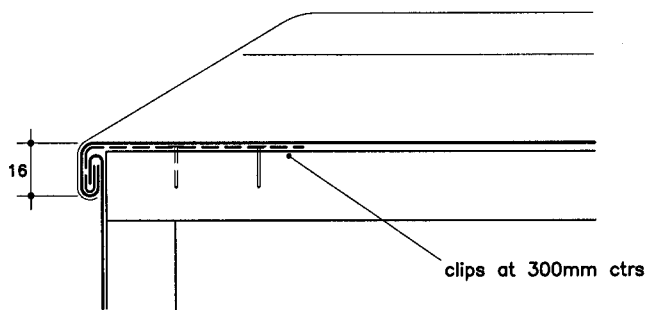

Fig 42b
Splayed batten roll end at parapet gutter
TRADITIONAL ✓ LONG STRIP X

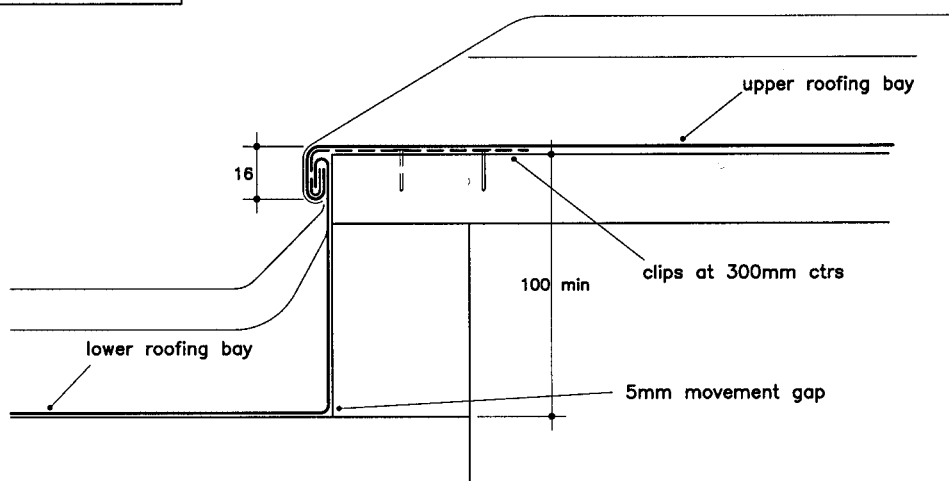

Fig 42c
Splayed batten roll end at drip-step
TRADITIONAL ✓ LONG STRIP X