

TRADITIONAL LONG STRIP

- * In Long Strip roofing, the 44 x 44mm batten is weathertight at roof pitches at and over 3degrees.
- * Fixed and sliding clips should be provided as set down in Table L p11. For small roofs in Long Strip roofing ie where roofing sheets do not exceed 3m, fixed clips may be used throughout.
- * Joints in the batten capping are made with single-lock welts as shown in Fig 36 (p87).
- * For on-site efficiency roofing sheets and cappings can be pre-formed in the workshop.

Temper: quarter- or half-hard
Thickness: 0.6mm or 0.7mm

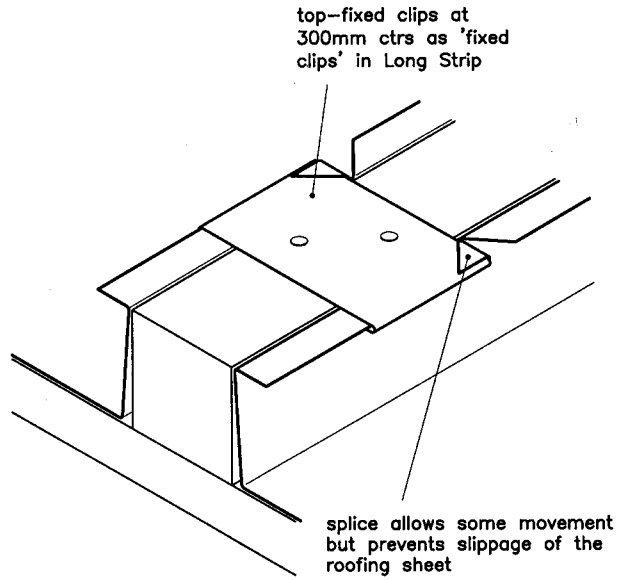
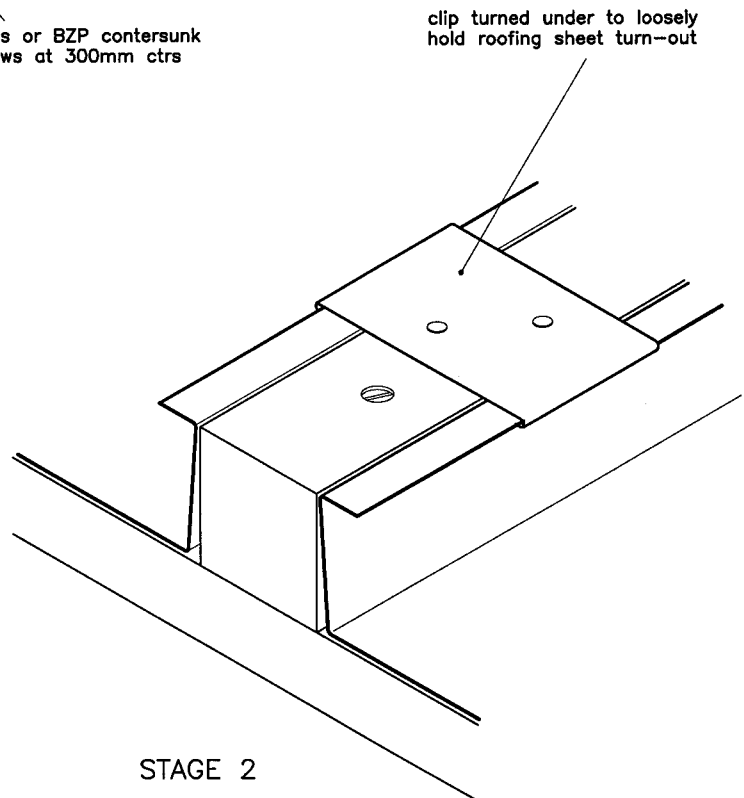
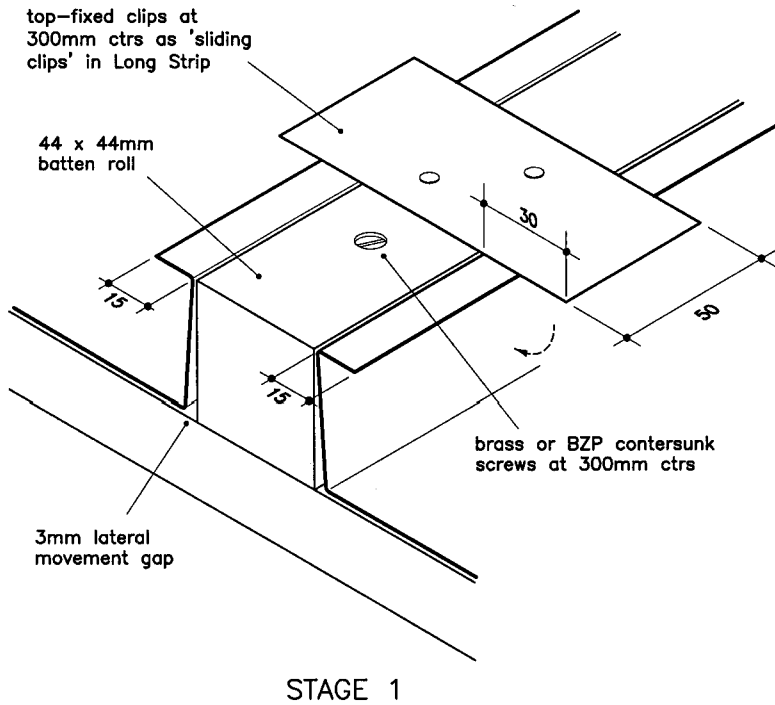

Fig 37a
Top batten clip as 'fixed clip'
TRADITIONAL LONG STRIP



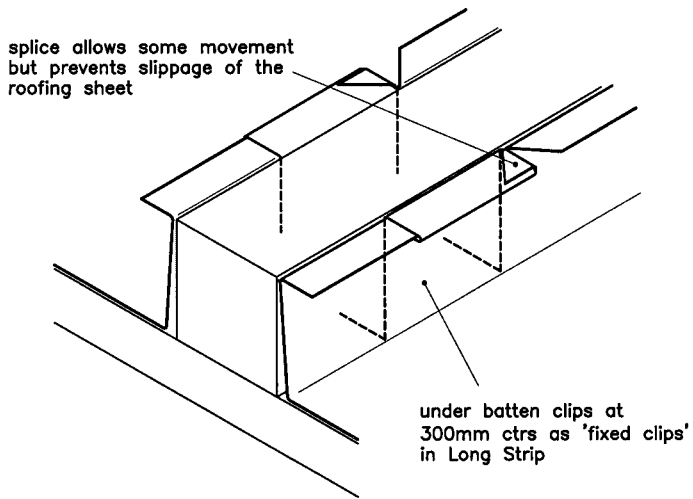

Fig 37b
Under batten clip as 'fixed clip'

TRADITIONAL LONG STRIP

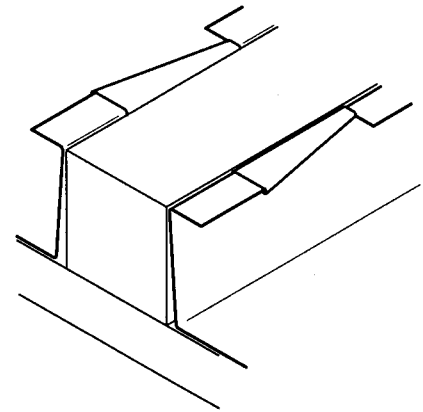
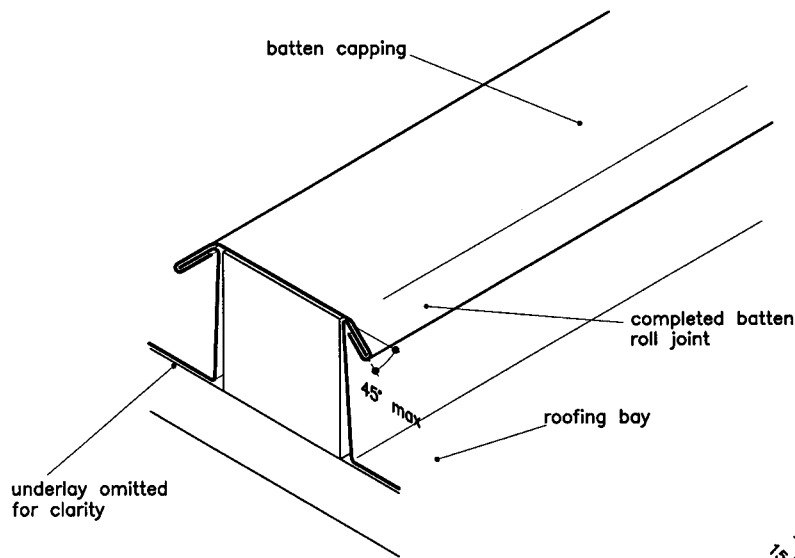

Fig 37c
Alternative under batten clip as 'fixed clip'

TRADITIONAL LONG STRIP



STAGE 3

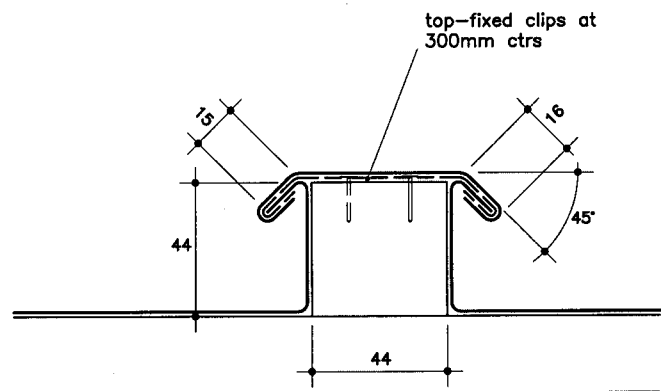

Fig 37d
Section completed joint

TRADITIONAL LONG STRIP