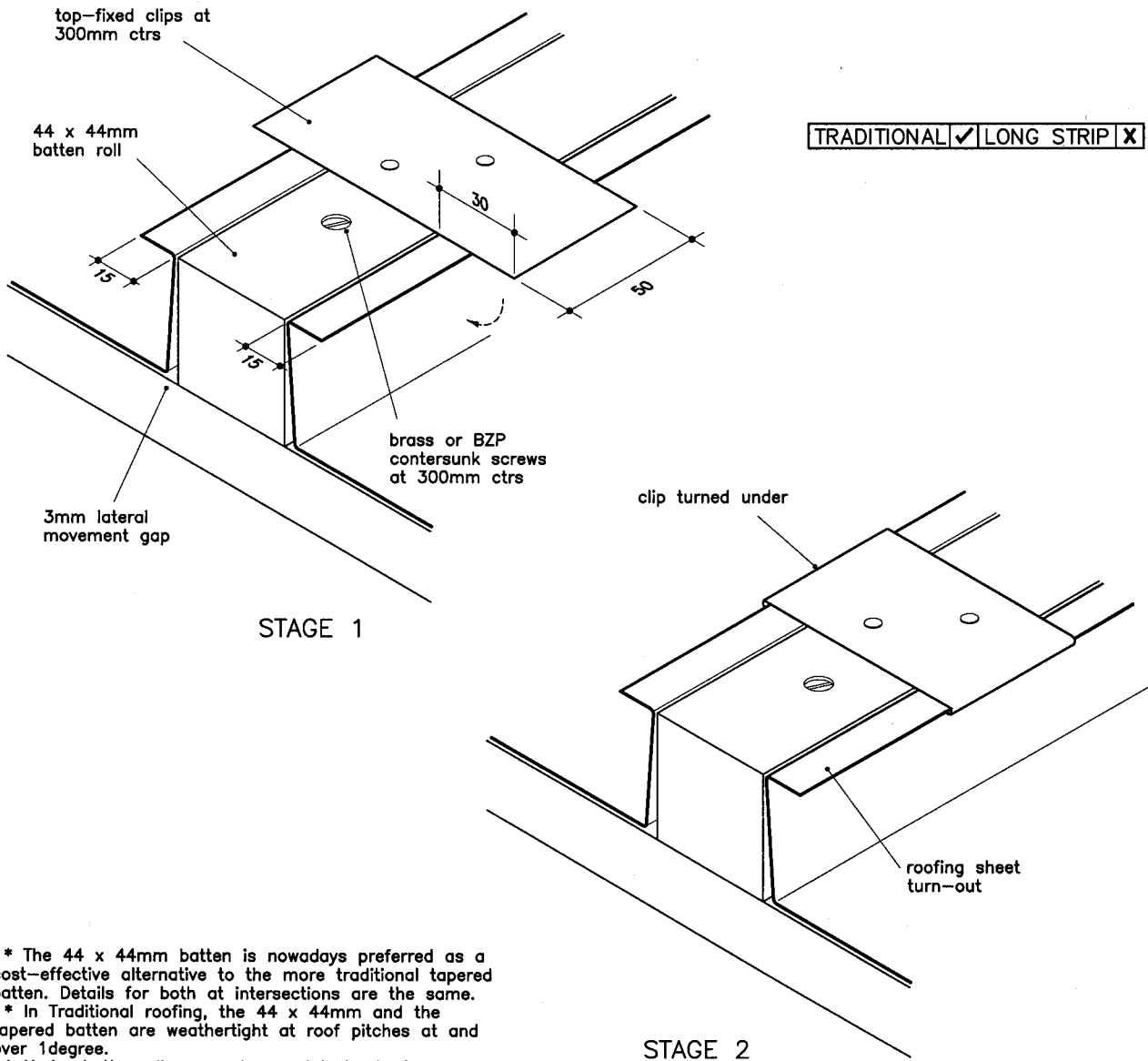

Fig 36 Batten roll joint in Traditional



* The 44 x 44mm batten is nowadays preferred as a cost-effective alternative to the more traditional tapered batten. Details for both at intersections are the same.

* In Traditional roofing, the 44 x 44mm and the tapered batten are weathertight at roof pitches at and over 1degree.

* Under batten clips may be used instead of top-fixed clips.

* For on-site efficiency roofing sheets and cappings can be pre-formed in the workshop.

Temper: soft, quarter- or half-hard
Thickness: 0.6mm or 0.7mm

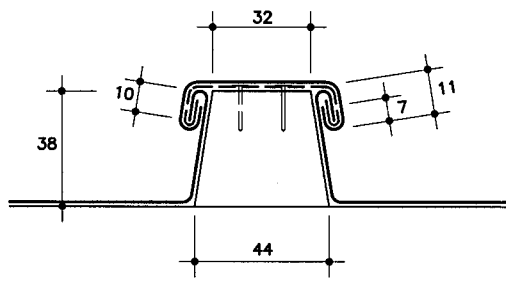

Fig 36a
Section tapered batten

TRADITIONAL ✓ LONG STRIP X

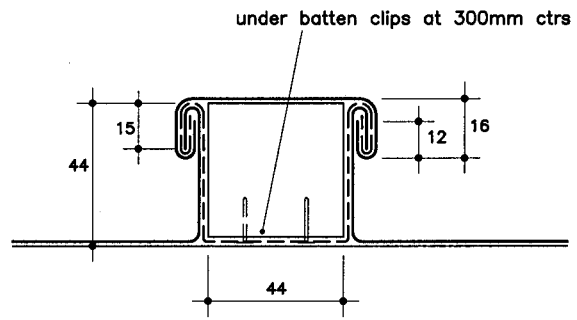

Fig 36b
Alternative with under batten clip

TRADITIONAL ✓ LONG STRIP X

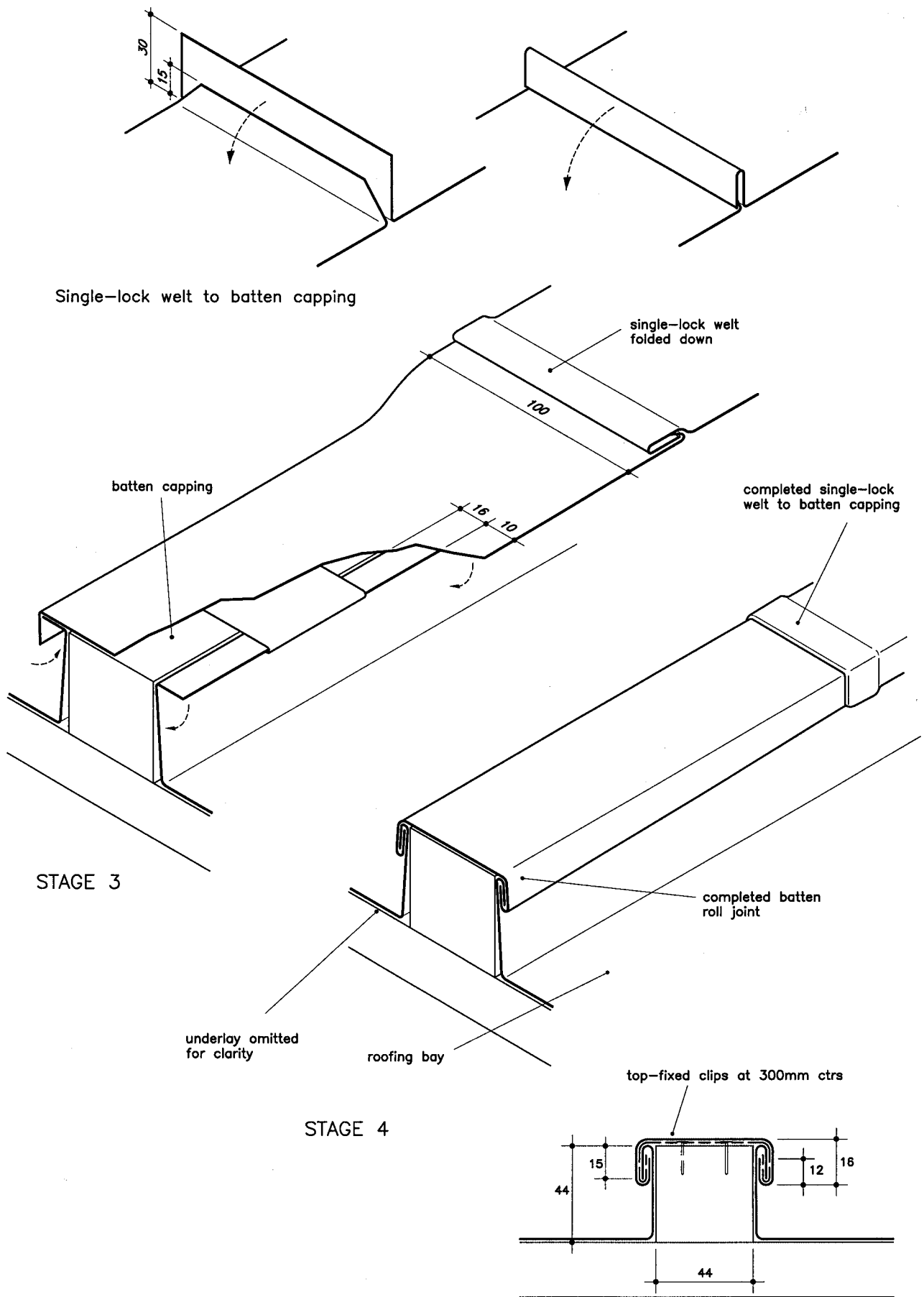

Fig 36c

Section completed joint

TRADITIONAL LONG STRIP