

Fig 34 ... with pitched valley single-lock welted to roofing sheets

This detail can only be used in Traditional roofing. In Long Strip roofing the lap-lock detail shown in Fig 33 (see opposite) would be used.

It is used where the pitches of the roofs discharging into the gutter are at or over 25degrees. This gives a minimum pitch to the valley gutter of 18.25degrees.

The roofing sheets are finished with a variation of the Concave-form seam end (see Fig 4) or the Turned-down seam end (see Fig 3).

If joints in the gutter are made using double-lock cross welts, they need to be at 3m maximum centres. The cross welts are clipped and longitudinal movement in the gutter is restricted. The clips along the edge of the gutter lining can be made to hold it tightly. The cross welts must be sealed with gutter pitches up to 20degrees.

However, ideally, gutter linings should be laid in one piece. Individual sections are joined by brazing, or soft-soldering with the joint strengthened by copper rivets. Alternatively the gutter lining is formed from one length of copper. Movement joints are needed, so that no section of gutter exceeds 10 metres in length (see Tables P and T, p13).

The most common way of forming such a joint is to use a vulcanised neoprene strip such as T-Pren. This type of movement joint is described in more detail in Fig 30 (p77). The lap-lock cross welt is also frequently used. It is important that the clips along the edge of the gutter should not hold it tightly, so that it can move in response to changes in temperature.

A waterproof underlay is recommended under the gutter lining. It should be carried up the roof for 450mm on each side of the centreline, to meet the main roofing sheet underlay.

Temper: Roofing sheet and gutter lining; soft or quarter-hard preferably, but half-hard is also possible.
Thickness: 0.6mm or 0.7mm

TRADITIONAL ✓ LONG STRIP ✗

Stage 2

Mark out the roofing sheets to the line of the gutter for forming the chosen seam end. Cut and cut away accordingly. Form a 30mm turn-under to the end of the roofing sheets, along the line of the gutter.

Stage 3

Hook the roofing sheets in position to engage with the check edge of the gutter. Seam up the roofing sheets as described in Fig 1 or Fig 2, on both sides of the gutter, and complete the seam end.

The standing seam undercloaks should face down the gutter.

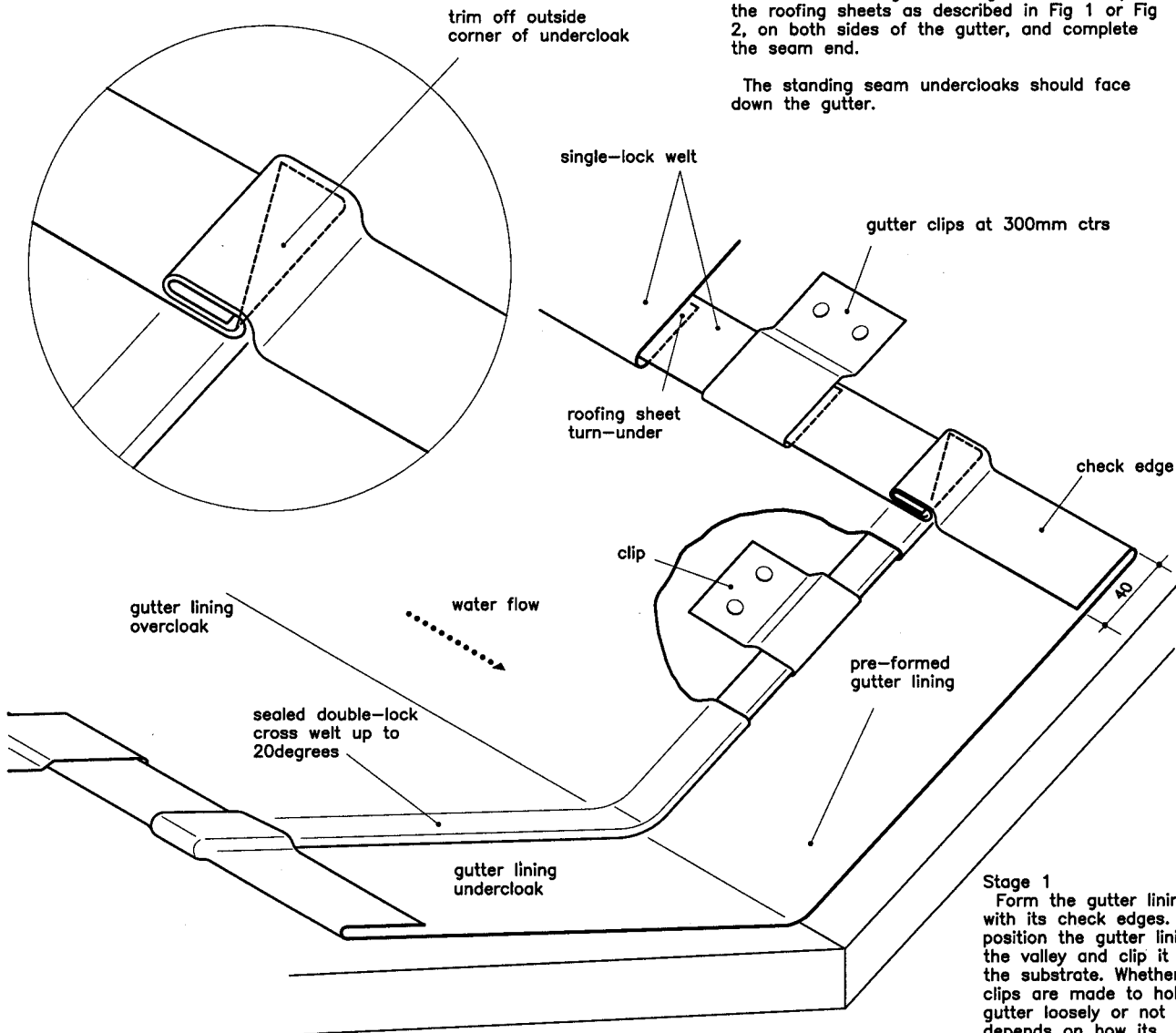

Stage 1

Form the gutter lining with its check edges. Then position the gutter lining in the valley and clip it to the substrate. Whether the clips are made to hold the gutter loosely or not depends on how its sections are to be joined (see Notes above).