

Fig 23 ... to ventilated monopitch roof over direct-fixed cladding

This detail is necessary for roofs which require ventilating to avoid the risk of condensation.

In Long Strip roofing (see Fig 23a below) the detail is basically the same but the roofing clips are formed to allow longitudinal movement.

Joints in fascias and ridge cappings are the same as for cover flashings. They should be at 2m maximum centres. They can be made with lapped joints: either 150mm or 50mm with a check edge and sealed; or with single- or double-lock welts, according to exposure and depth (see Figs 12b, 11a, 11b and 11c). With fascias where the depth is over 100mm, and with deep cappings such as that shown in Fig 20, welted joints are recommended to hold the copper neatly in line. The return folds of the welts are pre-formed. Double-lock welts in particular will be difficult to form in this situation and should be pre-formed.

More detail on direct-fixed cladding is given in Fig 29 (p76)

Temper: Roofing sheet with straight dog-eared upstand; soft, quarter- or half-hard. Pre-formed fascia; half-hard.  
Cladding: quarter- or half-hard.  
Thickness: 0.6mm or 0.7mm

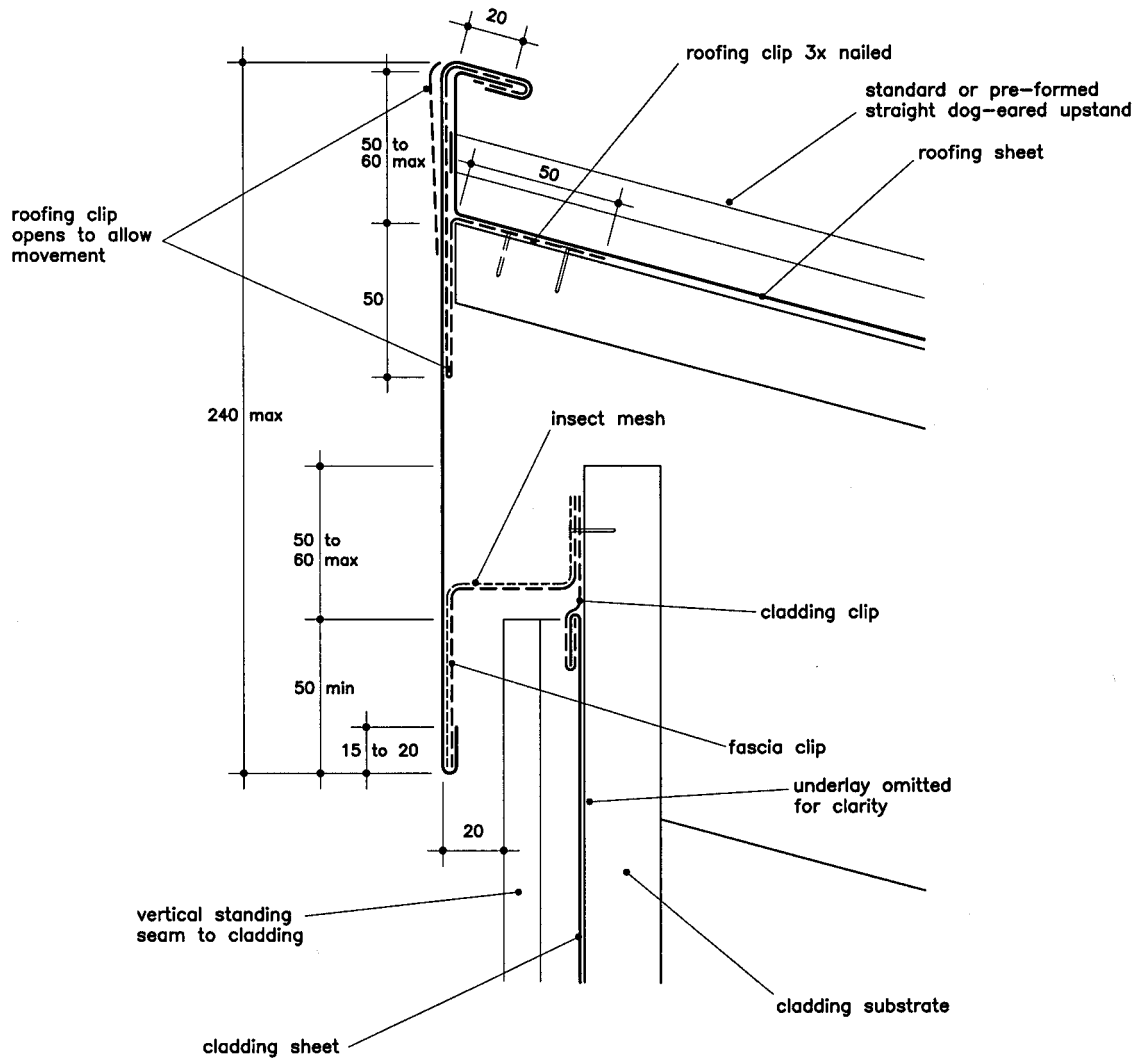

Fig 23a  
Showing movement clip used in Long Strip roofing

TRADITIONAL  LONG STRIP

Stage 1

Finish off the direct-fixed vertical cladding with a 15 to 20mm turn-down, to engage cladding clips at 2no per bay. Use cranked seaming pliers. Nail pre-formed fascia clips to the substrate, at 1no per bay located at the centre. Then nail in place the pre-formed insect mesh at 100mm centres.

TRADITIONAL ✓ LONG STRIP ✓

Stage 2

Nail roofing clips at 300mm centres along the ridge line. Finish off the roofing sheets to engage these clips with the chosen version of a straight dog-eared upstand (see Figs 9 and 10).

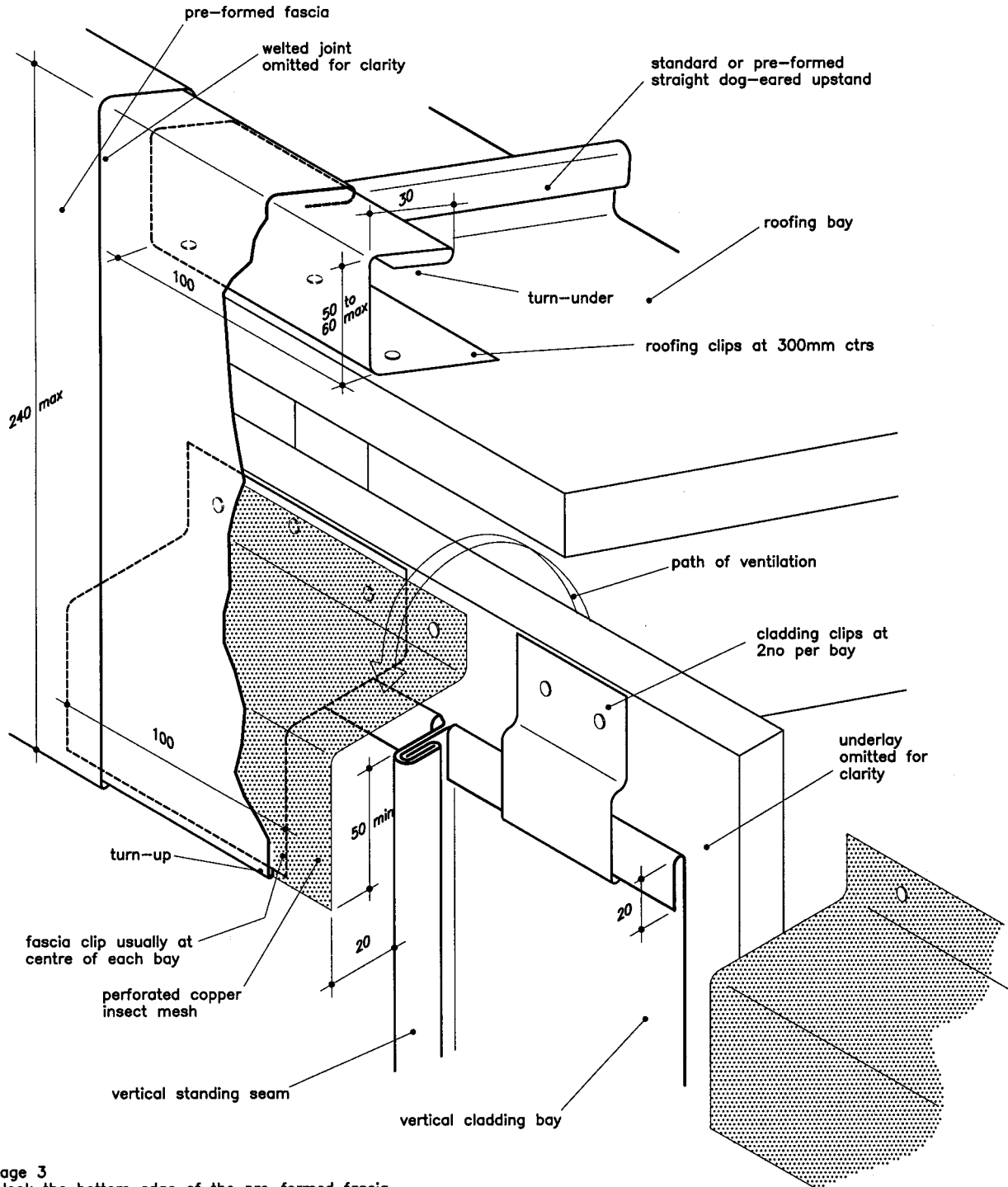

Stage 3

Hook the bottom edge of the pre-formed fascia around the fascia clips; and, using seaming pliers, complete the fixing at the top with a turn-under to engage the upstand already formed.