

This upstand is only possible in Traditional roofing. The copper sheets are worked and joined on the surface of the substrate and pushed up against the drip or upstand fully formed. The maximum sheet length of 1800mm now permissible makes this a practical proposition.

Temper: soft or quarter-hard, preferably. If half-hard is used the sides of the copper sheet must be cut tapered to the start of the splay as shown.
Thickness: 0.6mm or 0.7mm

The minimum upstand dimension that can be formed, excluding any turn-out, is 50mm.

The cutting away shown at Stage 1 is not essential, but it does make the folding of the upstand easier, especially when using half-hard copper.

TRADITIONAL ✓ LONG STRIP X

Stage 1

Mark out copper sheets and cut as shown. It is best to use a template so that each upstand is identical. This gives a consistent appearance and ensures that any cover flashing fits neatly. The marking out is the same whatever the roof pitch.

If profiled trays are being used the ends of the sheets will need to be flattened for marking out and cutting. Use straight snips for cutting.

STAGE 1

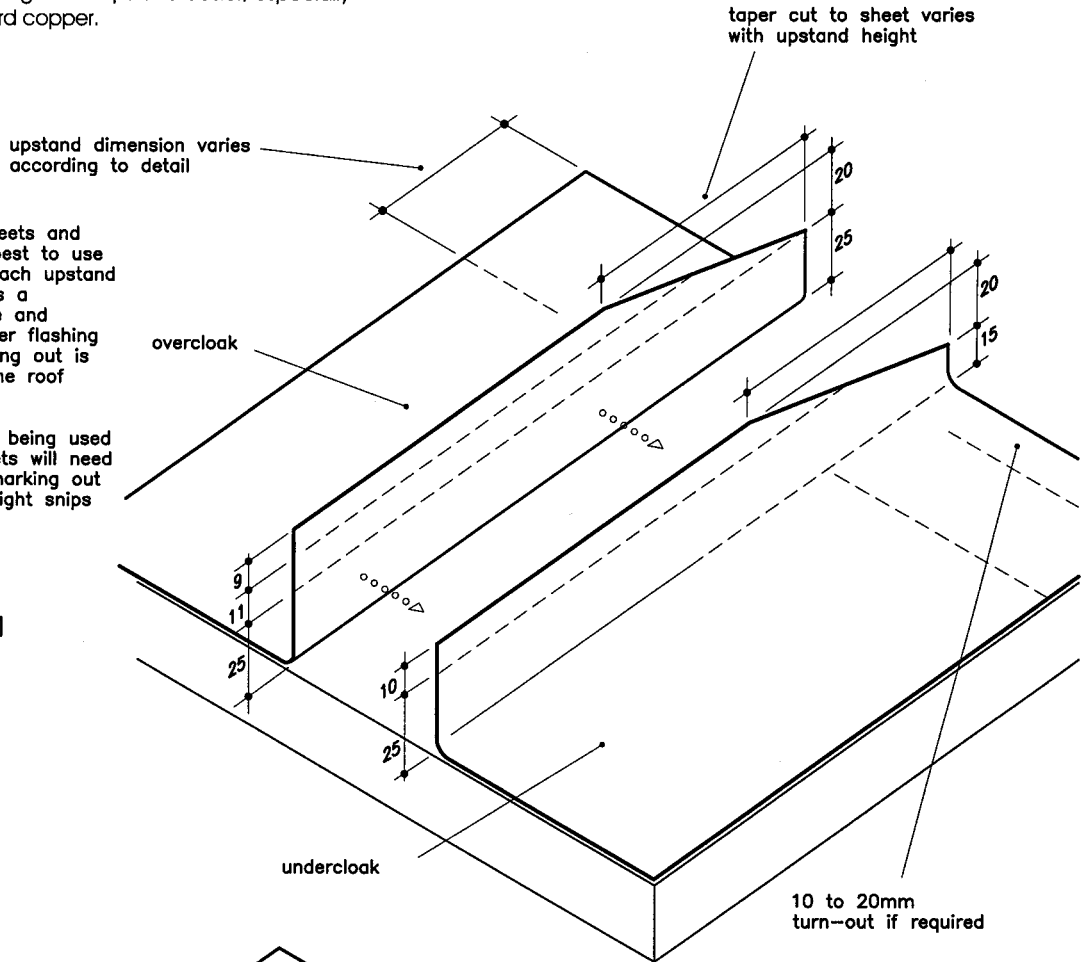

STAGE 2

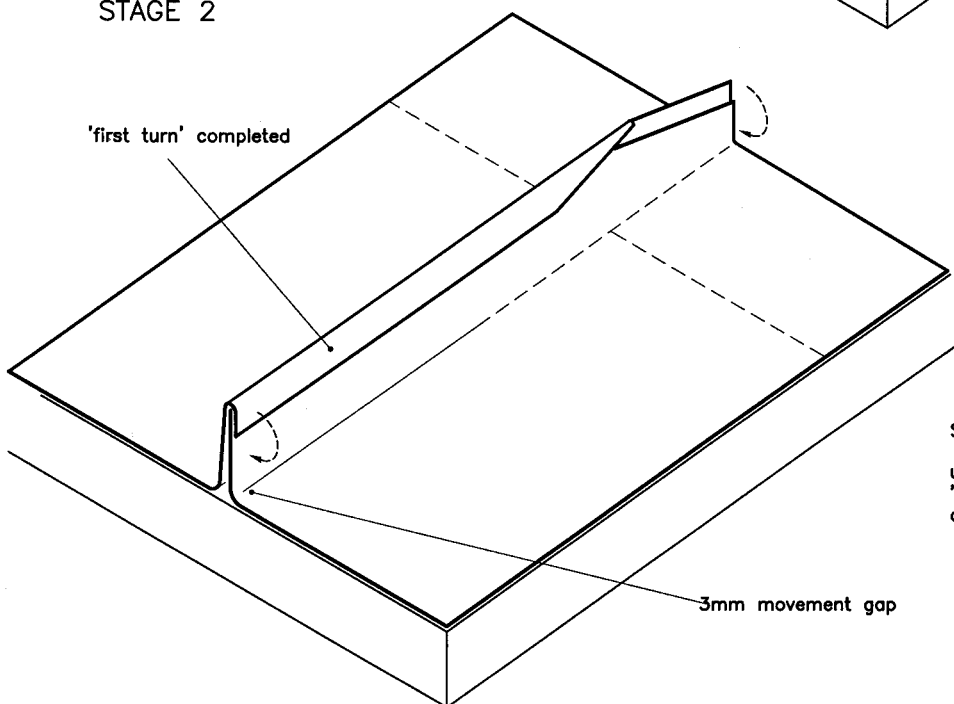

Stage 2

Dress overcloak over and down using a seaming iron, placed with 'first turn' iron against undercloak, and a wooden seaming mallet.

Stage 4

Dress standing seam over onto copper upstand using a wooden seaming mallet. Make sure that all seams are turned down from the same point to achieve a neat appearance. This will be 100mm minimum from the upstand fold.

STAGE 4

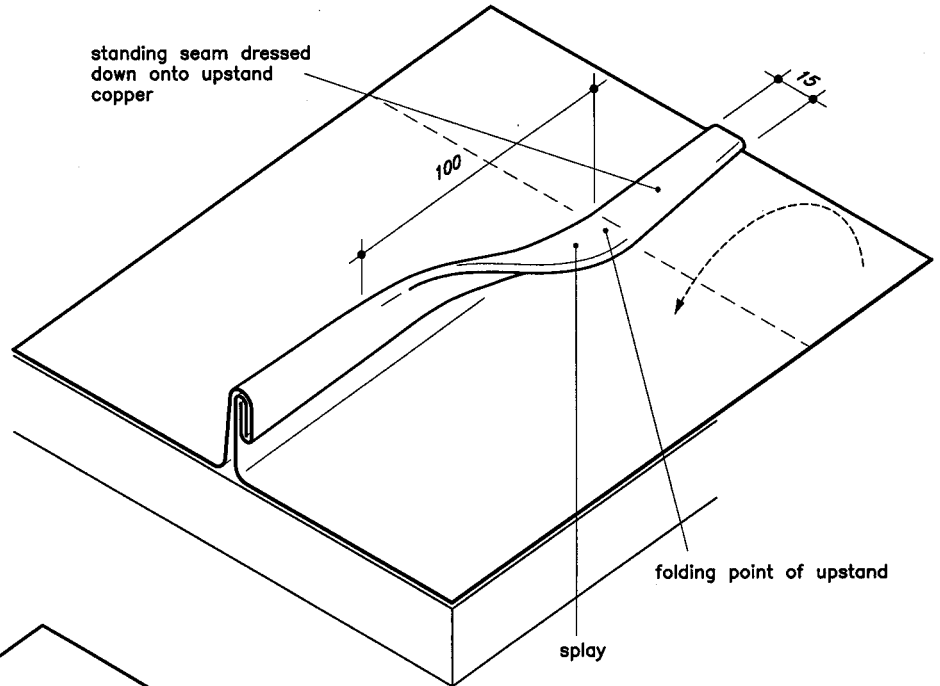

STAGE 3

standing seam completed

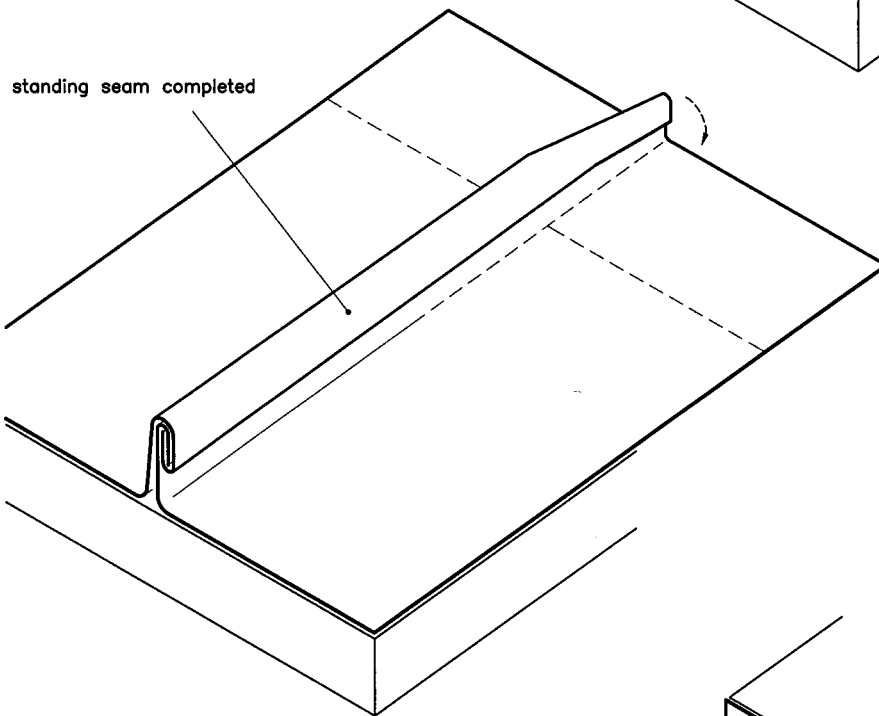

Stage 3

Dress overcloak and undercloak over and down to complete the joint.

STAGE 5

Stage 5

Fold the upstand into the upright position. In doing this a radius 5mm minimum should be made at the base of the upstand copper, rather than a sharp angle. It will be necessary to indent the seam at the folding point with the blade head of a hammer to start the fold.

Slide the roofing sheets into their correct position against the step.

Form the turn-out to receive clips, lining plate, roofing copper to upper bay, capping etc, according to detail.

underlay omitted for clarity

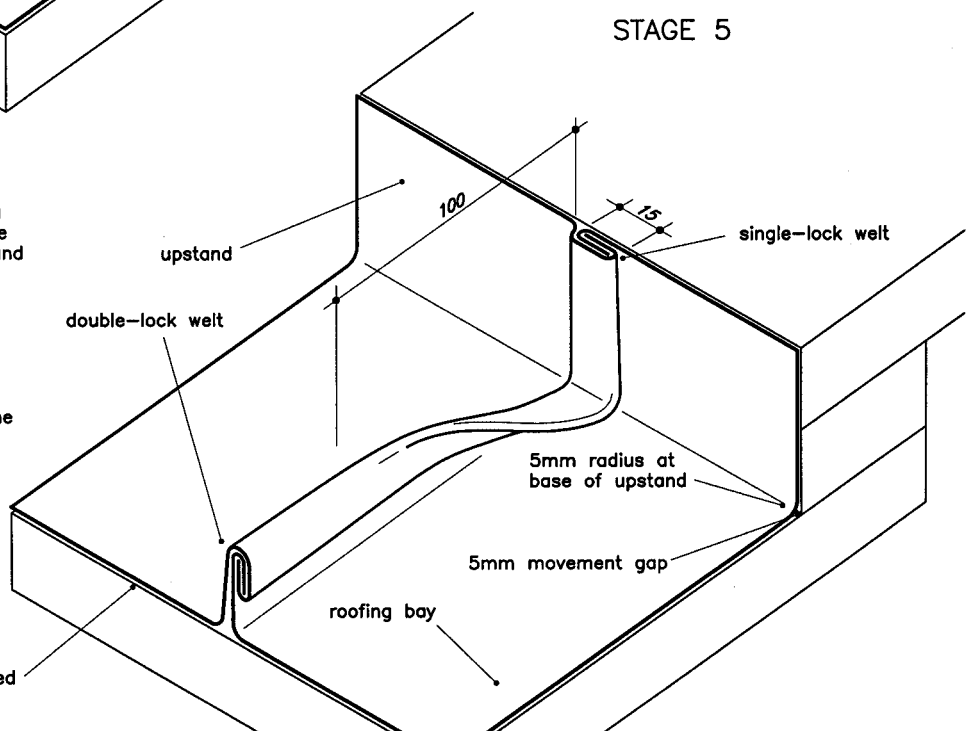

* In Traditional roofing the Turned-down seam upstand (see Fig 11) or a sweep-type standing seam upstand folded over (see Figs 7 and 18) is used.
 * In Long Strip roofing this sort of welted flashing detail is not possible. Instead use the Sweep standing seam (see Fig 7a) or the Pinched seam upstand (see Fig 12a).
 * Joints in cover flashings should be at 2m maximum centres. They are made with lapped joints: either 150mm as shown; or 50mm with a check and sealed (see Fig 12b).
 * The turn-up of the cover flashing is cut away at 45degrees at joints in the run. Similarly at the check edge in the brick course.

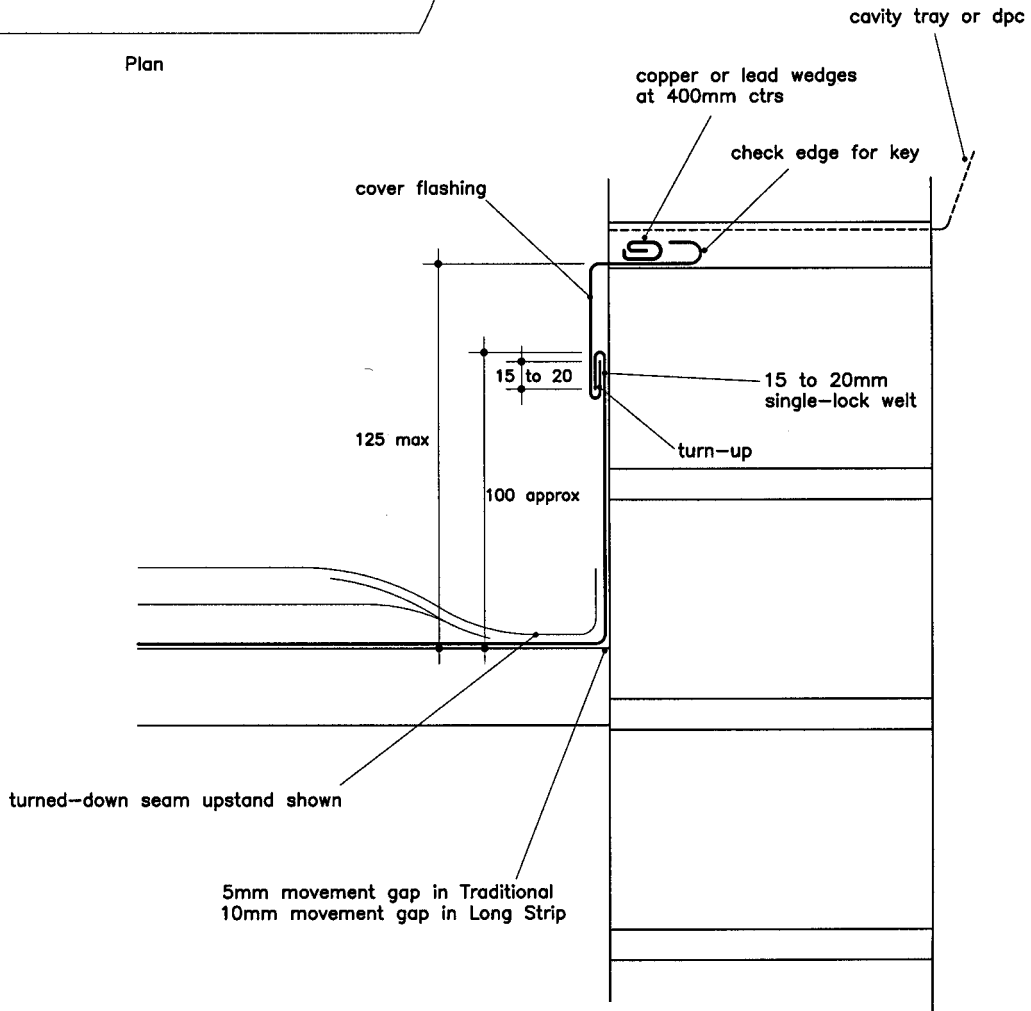
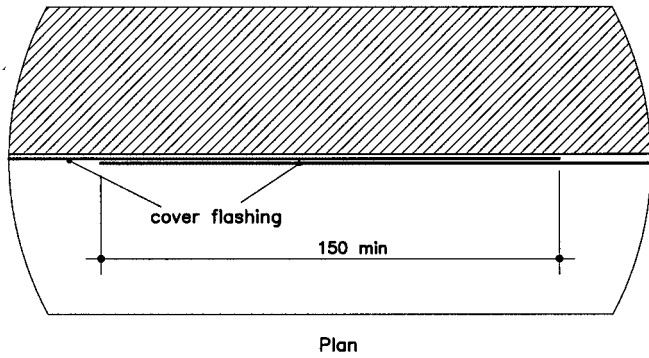
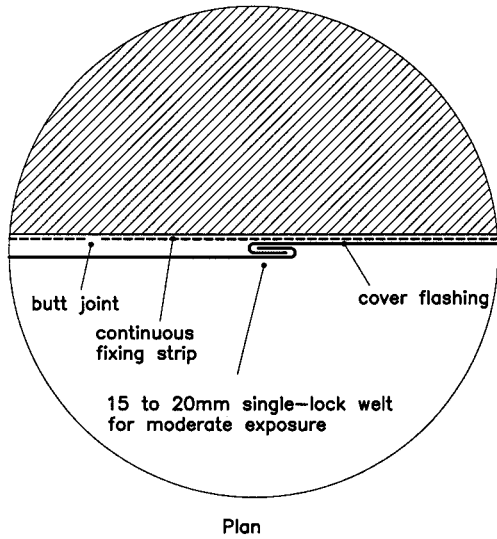

Fig 11a
 Vertical upstand 125mm max with horizontal cover flashing to brickwork
 TRADITIONAL ✓ LONG STRIP ✗



- * For Traditional roofing see Note to Fig 11a opposite.
- * For Long Strip roofing see Note to Fig 11a opposite.
- * The continuous fixing strip is fixed to the brickwork with 32mm No8 round head screws at 300mm centres, together with washers and plugged.
- * Joints in the continuous fixing strip are butt jointed.
- * Joints in cover flashings should be at 2m maximum centres. They can be made with lapped joints: either 150mm or 50mm with a check and sealed; or with single- or double-lock welt, according to exposure (see Figs 11a, 11c and 12b). Double-lock welts will be difficult to form in this situation and should be pre-formed.
- * The turn-up of the cover flashing is cut away at 45degrees at joints in the run. Similarly at the check edge in the brick course.

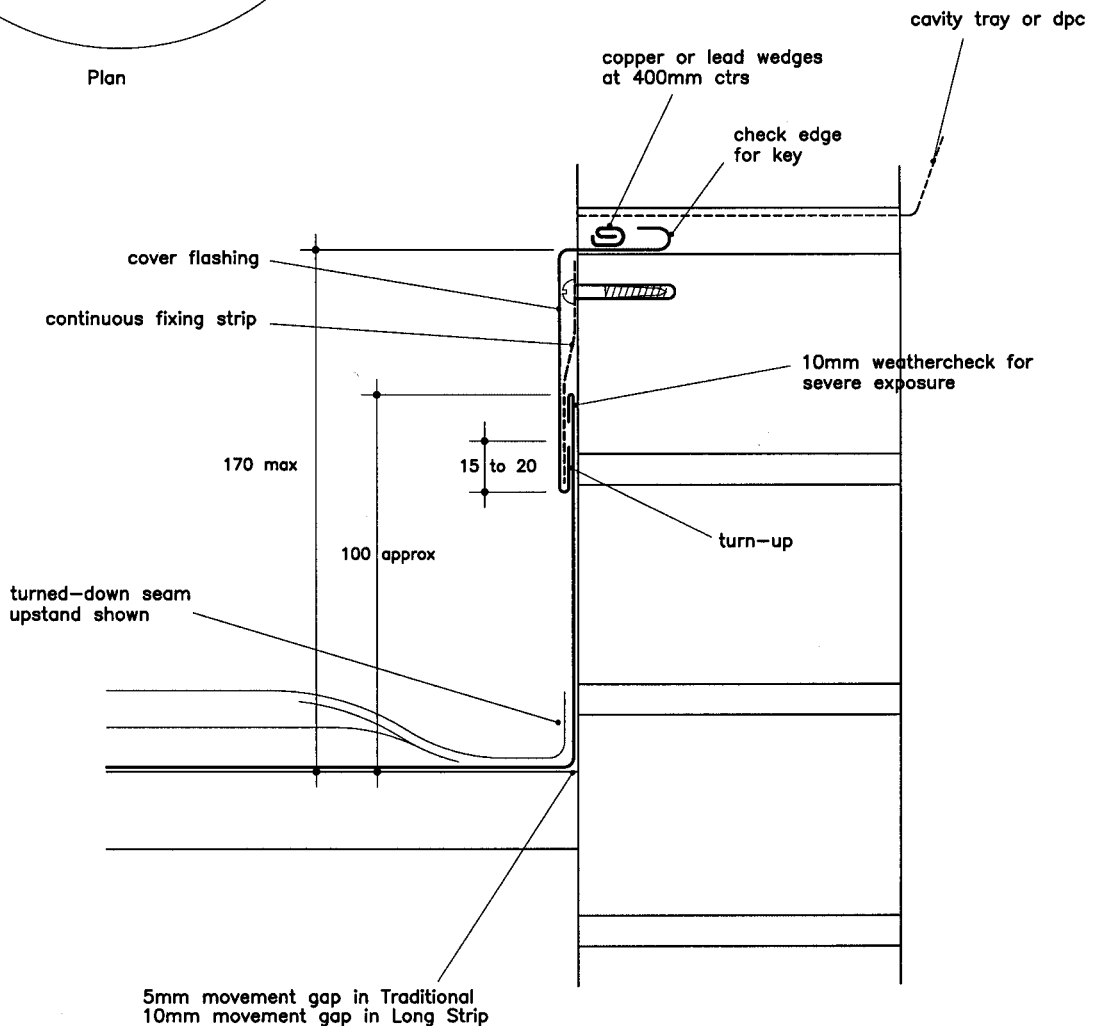

Fig 11b
Vertical upstand 170mm max with horizontal cover flashing to brickwork

TRADITIONAL LONG STRIP

- * For Traditional roofing see Note to Fig 11a (p44).
- * For Long Strip roofing see Note to Fig 11a (p44).
- * The continuous fixing strip is fixed to the brickwork with 32mm No8 round head screws at 300mm centres, together with washers and plugged.
- * Joints in the continuous fixing strip are butt jointed.
- * Joints in cover flashings should be at 2m maximum centres. They can be made with single- or double-lock welts, according to exposure (see Fig 11b). Double-lock welts will be difficult to form in this situation and should be pre-formed.
- * The turn-up of the cover flashing is cut away at 45degrees at joints in the run. Similarly at the check edge in the brick course.

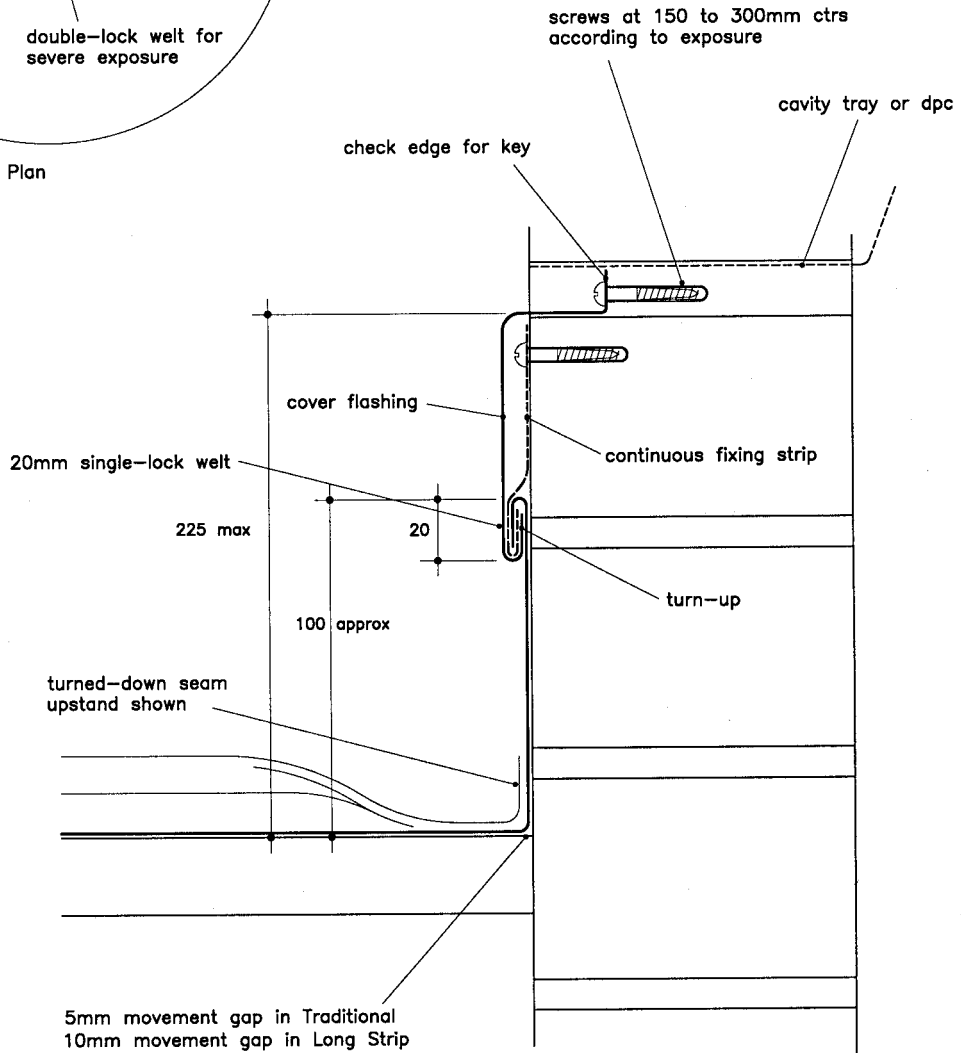
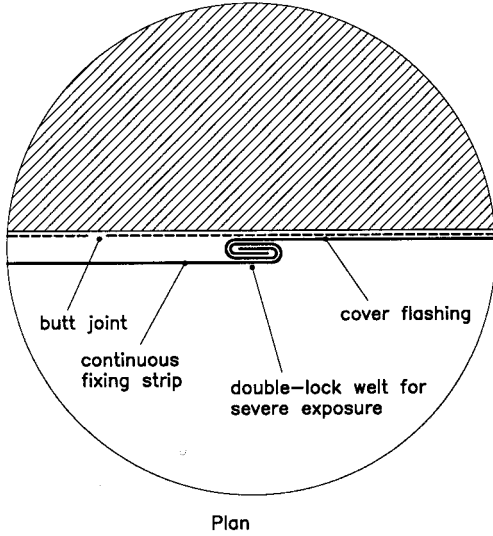

Fig11c
Vertical upstand 225mm max with horizontal
cover flashing to brickwork

TRADITIONAL LONG STRIP