

Fig 10 Pre-formed straight dog-eared upstand

This is a variant of the standard Straight dog-eared upstand (see Fig 9). It is an easy detail to form and allows most of the folding to be done in the workshop. It is a useful detail for drip-steps, batten ridges and batten hips.

The seam does not carry round the back of the upstand as in the standard version. This makes the detail less weathertight and for this reason is not recommended for roof pitches below 25degrees.

Unlike the standard version, access is not needed behind the upstand to complete the joint, so no 'drop-in' section of substrate or batten is required.

The upstand height is limited to 60mm maximum. This is to limit the exposure of the vertical joint.

As the trays will usually have been preformed in the workshop, the profiling machine automatically provides the 3mm gap needed to allow for lateral movement in the copper sheet.

TRADITIONAL ✓ LONG STRIP ✓

Temper: soft, quarter- or half-hard
Thickness: 0.6mm or 0.7mm

Stage 2

With the roofing sheets in position, bring the overcloak upstand up to the roof-pitch angle with straight flat-nosed pliers, thus forming a dog-ear fold. In doing this a slight radius should be made at the base of the upstand copper, rather than a sharp angle. The folding creates a back-flap standing in line with the seam. Then fold the back-flap round behind the upstand using pliers and dress tight against an 'H' seaming iron with a mallet [1].

Now bring the undercloak upstand up to match the other, also with a dog-ear fold. The back-flap for the undercloak automatically forms in line with the upstand.

Slide the undercloak into its correct position against the step [2]. Engage the overcloak with the undercloak [3] and close up roofing seam using seaming pliers or a seaming iron and a mallet.

STAGE 2

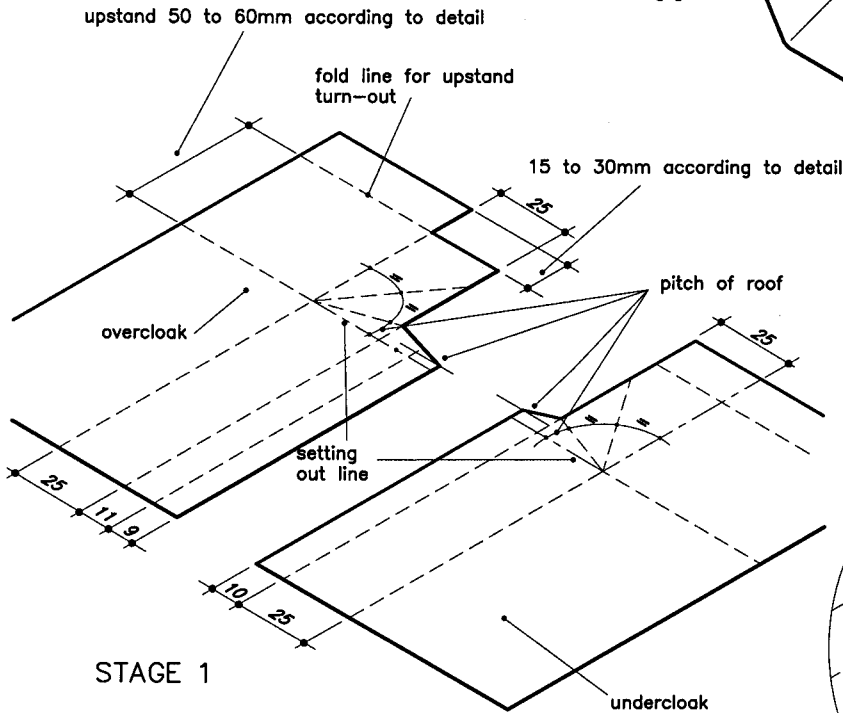
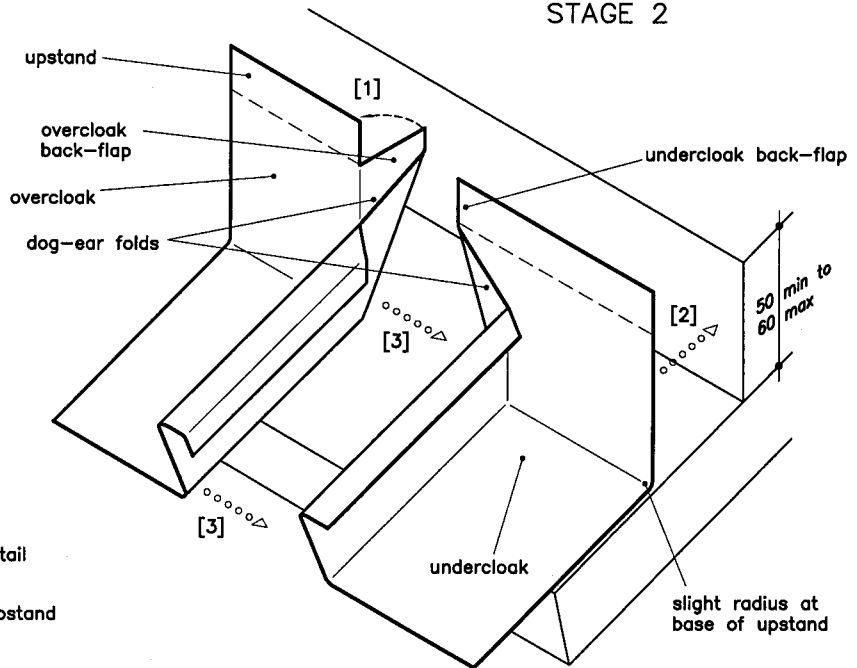

STAGE 1

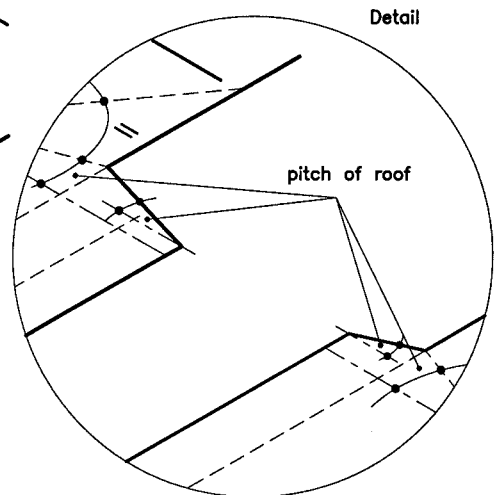

Detail

Stage 1

In the workshop mark out copper sheets and cut as shown. It is best to use a template so that each upstand is identical. This gives a consistent appearance and ensures that any cover flashing fits neatly. Note that the marking out gives the roof pitch and varies accordingly.

Use straight snips for cutting.

STAGE 3

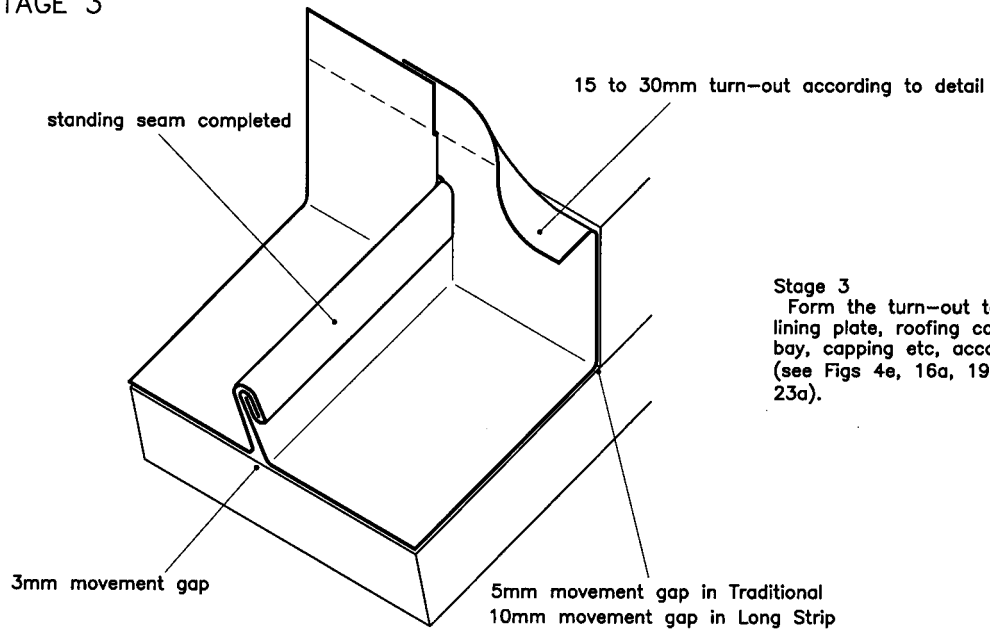

Stage 3
Form the turn-out to receive clips, lining plate, roofing copper to upper bay, capping etc, according to detail (see Figs 4e, 16a, 19, 21, 23 and 23a).

STAGE 4

Stage 4
The seam upstand is complete.

