

Fig 1 Hand-formed double-lock standing seam

This method of forming standing seams was commonly used before the widespread introduction of profiling machines. It is still used for short bay lengths and can be used for both vertical and horizontal joints in cladding.

In roofing its minimum pitch unsealed is 6degrees. With a non-hardening sealing strip such as Illmod, pitches down to 3degrees are possible, depending on exposure. Whether to seal or not should be discussed with the copper roofer. Linseed oil is still preferred as a sealant by some roofers.

If a really precise appearance is required it would be better to specify 'roll-formed' seams as shown in Fig 2 (p18).

For bay widths taken from seam centre to seam centre see Tables E (p8) and J (p10). Also see Tables M and N (p12).

The sequence notes describe the seam being formed using a seaming iron and a wooden seaming mallet. It is equally possible to use a hand-operated angle seamer to Stage 3, with a double seamer to complete Stage 4. This is both quicker and achieves a more consistent seam height.

Temper: soft, quarter- or half-hard
Thickness: 0.6mm or 0.7mm

TRADITIONAL ✓ LONG STRIP ✓

* Minimum dimensions shown. Clips are more often 50mm wide.
* In most detail locations clips are spaced at 300mm centres, but see also Table L (p11).

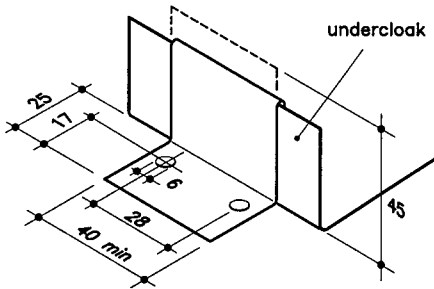
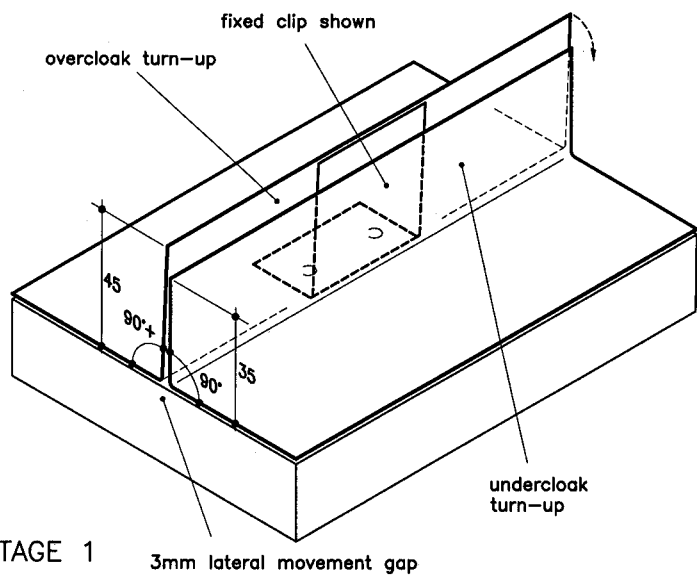

Fig 1a Fixed clips

TRADITIONAL ✓ LONG STRIP ✓



Stage 1

Form edge turn-ups for overcloak of 45mm and for undercloak of 35mm, using folding machine or universal flat-nosed pliers. The angle at the base of the 45mm turn-up is greater than 90 degrees to allow for lateral movement in the copper sheet.

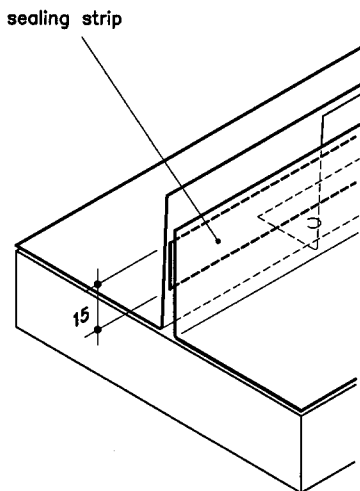

Fig 1c Sealing strip for pitches below 6degrees

TRADITIONAL ✓ LONG STRIP ✓

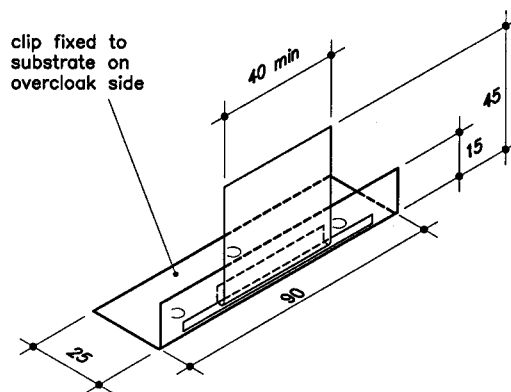
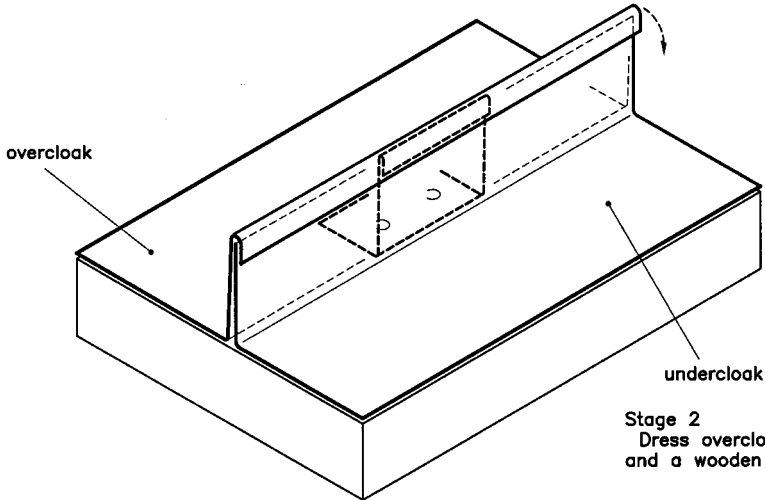

Fig 1b Sliding clip

TRADITIONAL X LONG STRIP ✓

* For spacing and positioning of clips, see Table L (p11).



Stage 2
Dress overcloak over and down using a seaming iron and a wooden seaming mallet.

STAGE 2

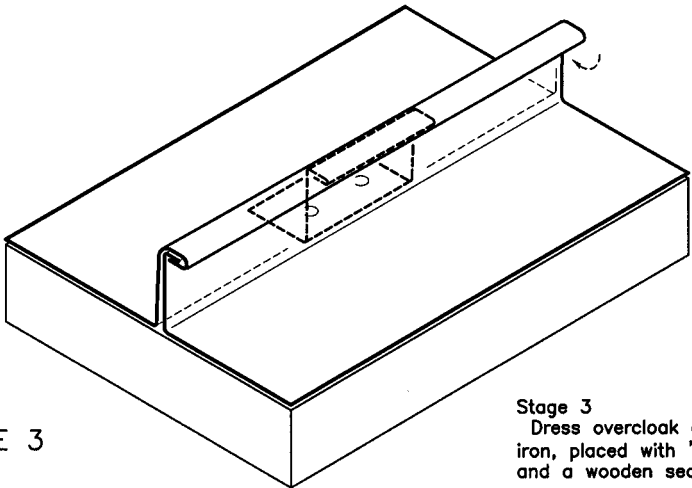

Stage 3
Dress overcloak and undercloak over using a seaming iron, placed with 'second turn' iron against undercloak, and a wooden seaming mallet.

STAGE 3

This is the final stage for the Angle standing seam. Note it can only be used at and over 25degrees roof pitch.

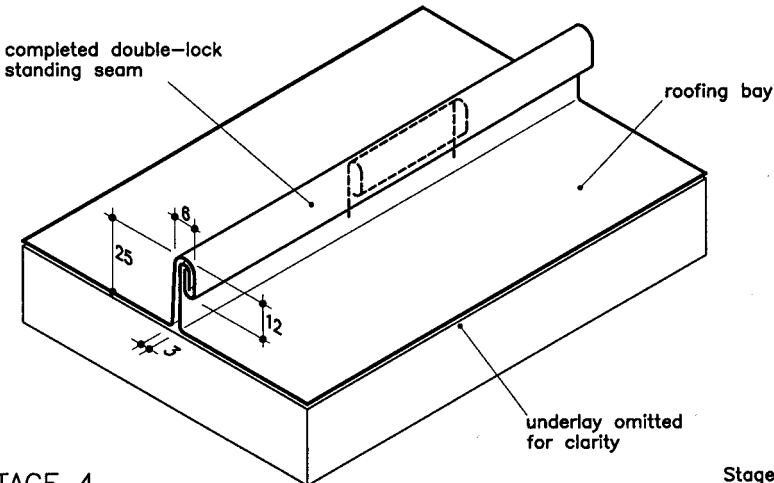

Stage 4
Dress seam down to complete the joint.

STAGE 4